

**A DURABLE FIBRE CEMENT & STEEL
COMPOSITE BUILDING MATERIAL**

DURASTEEL®
DUCTING

Intumex®
ASIA PACIFIC



Introducing DURASTEEL® Ducting

Features

- Fire resistant from either side.
- Impact resistant.
- Moisture resistant.
- Space-saving.
- Complete system.
- Excellent structural strength and integrity.
- Suitable for internal and external locations.
- Maintenance-free.
- Can be prefabricated.
- Low leakage.
- Suitable for Class C pressure differential of -750 Pa and +3,500 Pa.
- No dampers needed.
- Protects services and maintains fire integrity of compartment walls and floors through which it passes.
- Fast track construction methods.

Types of Application

- Smoke exclusion.
- Smoke extraction.
- Fresh air ventilation.
- Kitchen extraction.
- Protection of building services.
- Pressurisation and purging.

Fire Rating Performance

- Up to 4-hour stability and integrity from either side.

General

Making the right choice of fire resistant ductwork is a minefield when legislative considerations have to be borne in mind, a decision that is further complicated when even the phrase “fire resistance” and “fire rated” can have totally different meanings and are sometimes used as performance indicators.

“Fire resistance” can be thought to imply that the duct performance includes all three parameters, Stability, Integrity and Insulation, whilst “fire rated” has no particularly definitive meaning and is often confused with “fire resistance” which has significant implications within the British Standards. This lack of clear definition alone creates a dilemma for designers who have to make a choice from sales literature that covers many different product types and performances.



BS 476 : Part 24: 1987

When interpreting BS 476: Part 24, the standard that relates directly to the performance of fire ducts, specifiers and designers also have to decide whether Type A (Fire outside only) or Type B (Fire inside and outside) is required. The selection of Type A or Type B will depend on the location of the duct and the type of fire risk in that particular area. It is vital that they make the right choice as Type A ducts which are for resistance to fire outside only will require a much lower performance capability than the more onerous demands required from Type B ducts.

The versatility of the DURASTEEL® range for ductwork means that customers can specify either Type A or Type B ducts and be safe in the knowledge that they have chosen a system which fully conforms to the performance requirements of BS 476: Part 24.

BS 5588 : Part 9

DURASTEEL® ducts comply with the method 3 construction in accordance with BS 5588: Part 9 “The ductwork itself forms a protected shaft. The fire resistance may be achieved by the ductwork material itself, or through the application of a protective material.” DURASTEEL® is self protective and requires no other form of lagging or protection.

Introducing DURASTEEL[®] Ducting

Specification for Fire Resistant Ductwork & Plenums

- The fire resistant ductwork shall be fabricated from 'DURASTEEL[®] or equivalent' sheets comprising a composite laminated board with circular perforations. Monolithic boards shall not be accepted. The fire resistant ductwork / plenum shall be either site or factory fabricated from fire resisting composite sheet material comprising of a fibre cement core mechanically bonded to outer skins of 0.5mm thick galvanised sheet steel.

The steel shall be punched to create circular perforations of nominal 5.5mm diameter on nominal 17.5mm grid pitch, the steel being bent inwards to form 'tines' which provide a mechanical key between the core and the steel sheets. The core and outer skins shall be pressed together to form a composite which provides strength in the sheet through 'tines' embedded in the core. Thickness of the composite material shall be described as 6.0 or 9.5mm thick depending on structural performance required.

- The fire rated ductwork shall have up to 240 minutes fire resistance, tested to BS 476 Part 24 (tested internally and externally) and further assessed by a UKAS accredited laboratory.
- Smoke extract ductwork which passes from one fire compartment to another shall have up to 240 minutes fire integrity, tested to BS 476 Part 24 Type B (tested internally and externally). Also to be proven by independent certification that the resulting cross sectional area of the duct at the end of the test shall have maintained at least 75% of it's original cross section.
- Pressurisation ductwork to escape stairways shall have up to 240 minutes fire integrity, tested to BS 476: Part 24 Type A (tested externally).
- Where fire resistant plenums are specified they shall have up to 240 minutes fire integrity, tested to BS 476: Part 22 (tested internally and externally) and shall include all support systems and fixings.
- Penetration seals around fire resistant ductwork shall be compliant with BS 476: Part 24 (i.e. they shall be installed as tested / assessed). Intumex Fire Seals shall be used, as is current practice for sealing around DURASTEEL[®] systems.
- All necessary supports, joining strips, flanges and other accessories required for the complete installation of the fire resistant ductwork / plenum systems shall be supplied by the same manufacturer as the Duct / Plenum fabricator.
- Independently tested fire resistant sealed access hatches shall be provided in the fire resistant ductwork / plenums to allow access for cleaning and maintenance of equipment such as fire dampers.



Continued on next page



Introducing DURASTEEL® Ducting

Specification for Fire Resistant Ductwork & Plenums *Continued from previous page*

- In addition to BS 476: Part 24 fire test requirements, the composite material used in fire rated ductwork and plenum constructions shall have proven its suitability for use, endorsed by independent certification (test or assessment), to meet the following performance parameters:

MECHANICAL	TYPICAL VALUES	TEST STANDARD
Flexural strength	84MPa <small>9.5mm DURASTEEL® ambient</small>	BS EN 12467:2000
Flexural Modulus	40GPa <small>9.5mm DURASTEEL® ambient</small>	BS EN 12467:2000
Impact strength	No failure 1500mm drop	BS 5669: Part 1:1989 Clause 21.4

MOISTURE	TYPICAL VALUES	TEST STANDARD
Absorption <small>Weight from normal moisture content</small>	6~7%	
Movement from 35% RH to 85% RH	≤ 0.02%	BS EN 318: 2002
Movement from 65% RH to saturated	≤ 0.02%	BS EN 318: 2002
Watertightness	Pass	BS 4624: 1981

THERMAL	TYPICAL VALUES	TEST STANDARD
Thermal conductivity at 20°C	0.129W/m ² K <small>9.5mm DURASTEEL® ambient</small>	ASTM C518: 1991
Coefficient of thermal expansion	15 x 10 ⁻⁶ K ⁻¹	BS 1902: 1990
Maximum continuous operating temperature	350°C	BS 7346: Part 2: 1990

FIRE	TYPICAL VALUES	TEST STANDARD
Effect of 4000J hard body impact test after the test	Pass	DIN 4102: Part 3
Non Combustibility	Pass	BS 476: Part 4: 1970
Effect of hose stream to 3.1 Bar	Pass	ASTM E119
Fire resistance after 24 hours water immersion	Satisfactory	BS 476: Part 24: 1987
Surface spread of flame	Class 1	BS 476: Part 7: 1987
Building regulations classification	Class 0	As defined in Approved Document B
Maximum tested fire resistance	360 minutes	Various

Continued on opposite page



Introducing DURASTEEL® Ducting

Continued from opposite page Specification for Fire Resistant Ductwork & Plenums

- Many boards that have good fire properties and claim to be moisture resistant are often rendered ineffective if they become soaked, perhaps by a leaking flange, condensation absorption, sprinkler actuation or services or building leakage. This test is vital to prove that the material will not explode as it goes through thermal shock as the hot gasses are drawn through the duct. If explosive delamination occurs, the systems fire resisting properties and ability to remove products of combustion are effectively lost.
- Impact resistance is vital to support both the life expectancy of the system and resist damage during the build and delivery of the system. Unexpected site conditions/delays often mean that ductwork sections will be stored on site in cramped conditions where damage could occur, resulting in programme delays
- Resistance to projectiles proves that during the operational life of the system objects that may be disturbed and/or thrown against the duct/plenum will not cause damage, hence preventing expensive maintenance and possible closure
- Vibration resistance testing is required because many of the ductwork systems may be located in non-accessible areas of the building or surrounded by other services which may prevent effective maintenance of the installed system during it's life. Operators will not want to carry out expensive out of hours inspections to the systems to check for cracking or pressure loss which could be caused by vibration action / air pressure extremes incident from passing trains etc.
- Non-combustibility and minimal smoke toxicity are vital characteristics of all the materials used throughout buildings, but are of especial importance for systems operating in underground rail stations for instance.
- Acoustic properties may be of vital importance where ducts pass through public areas and helps stop drumming and airborne sound transfer
- Leakage tests provide assurances as to the systems ability to retain its specified operating pressure throughout its lifetime.
- Airflow resistance test provide designers with information to allow fan sizing.
- Strength testing will verify the materials 'Walk on strength', the materials strength when wet and the resistance to delamination of the outer steel skins.



There are a number of differing DURASTEEL® duct systems, all designed and fully tested so as to be able to offer a variety of systems and solutions suiting a wide range of construction needs and performance requirements. These are described in brief in the following pages. For specific performance requirements and installation details, please consult your local Intumex Asia Pacific office.



DURASTEEL® Ducting Design Considerations

Provision of Natural & Mechanical Basement Smoke Vents

Smoke and heat tends to escape from basement areas via stairways and lift shafts. This makes escape, fire fighting and search and rescue more difficult.

Venting of basement areas reduces this problem and also provides the fire services with the means to allow cooler air into the the basement which facilitates access and smoke clearance.

A large modern building with a basement greater than 200m² in area and/or more than 3 metres below ground level is unlikely to be catered for by natural ventilation alone. Basements of this size served by mechanical smoke extract systems must also be sprinklered.

NATURAL SMOKE VENTS

- Where practicable each basement space should have one or more smoke vents.
- Smoke vents ⑦ should be situated at high level, evenly distributed around the building perimeter, discharging to atmosphere.
- Places of special fire hazard should have separate vents.
- Vent terminations ⑥ may have non-combustible break-out covers grilles or louvres. Vents must not obstruct means of escape.

- The combined cross-sectional area of all the smoke vents must not be less than 1/40th of the floor area of the storey that they serve.
- Vent ducts or shafts ⑦ should be constructed of non-combustible fire resisting materials.
- Where natural smoke vent shafts from different compartments of the same basement storey, or from different basement storeys, are adjacent to each other. They should be separated by non-combustible fire resisting construction.

MECHANICAL SMOKE VENTS

- The air extraction system should give at least 10 air changes per hour.
- The air extraction system ① should be rated at 300°C for 1 hour minimum. The fan is to be located in a 1-hour minimum fire compartment if the fan room is located within the building.
- The duct system must activate automatically, either by activation of the sprinkler system or by an automatic fire detection system.
- Where the ductwork passes through fire resistant walls or floors the system must have been tested to BS 476: Part 24: 1987.

- The system must retain 75% of its cross sectional area to be suitable for use of smoke extraction purposes.

Ref: BS 476: Part 24

- A sprinklered system ⑤ should be fitted to the basement storey(s) where a mechanical smoke extract system fulfils the main extract requirements.
- The protected shaft ② encloses the ductwork.
- The air extraction system should give at least 10 air changes per hour.
- Penetration sealing ③ at compartment walls and floors is to be as used in fire testing of the duct system.

Ref: BS 476: Part 24

- The duct system identified within the protected shaft, plant room and basement area may be upgraded with insulating material over escape routes ④ or adjacent to potential fire hazards, to provide full fire insulation to BS 476: Part 24.

DURASTEEL® Ducting Design Considerations

Provision of Natural & Mechanical Basement Smoke Vents

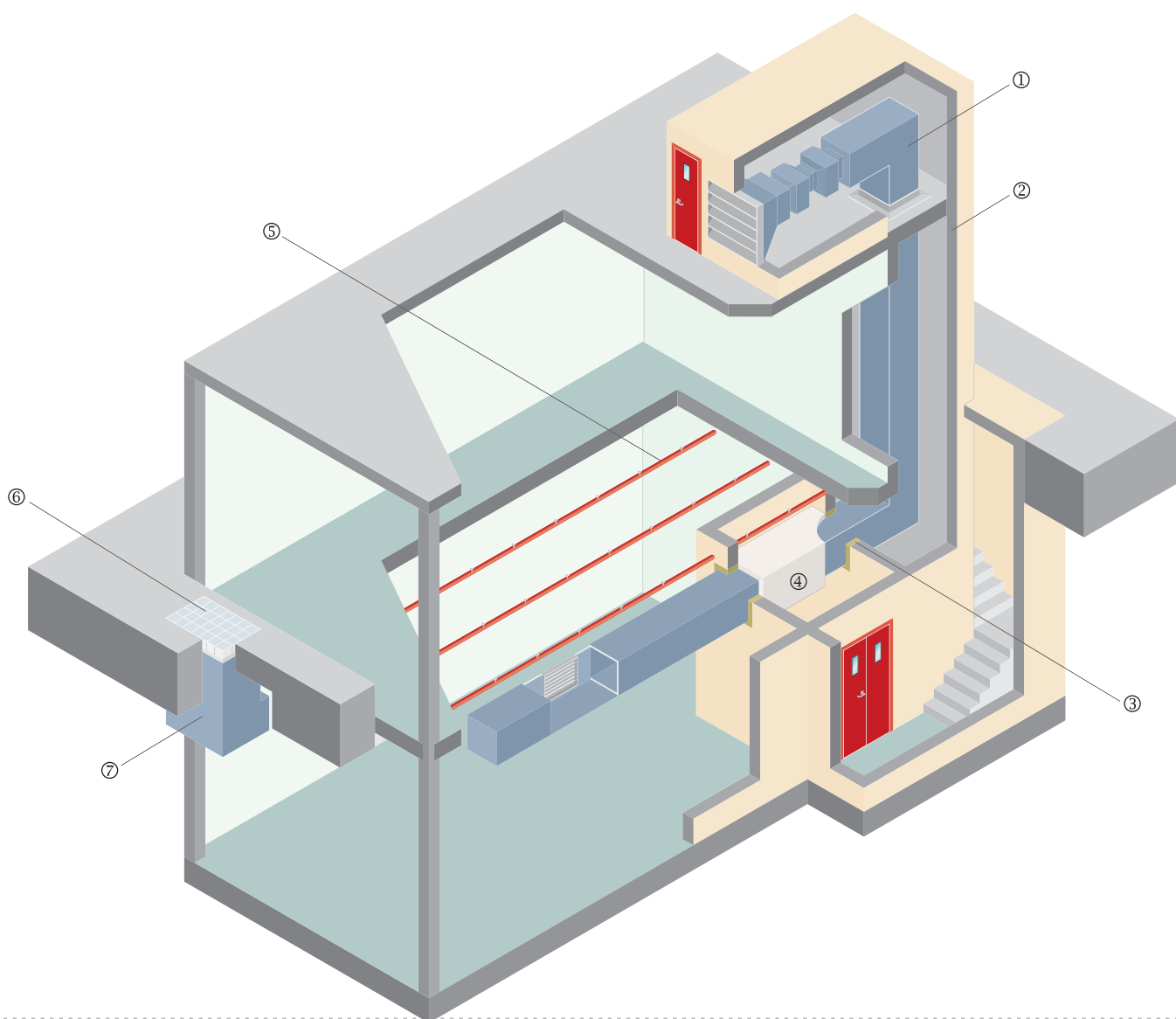

REFERENCE DOCUMENTS

- BS 476: Part 24: 1987.

REPLACEMENT AIR

When mechanical smoke extraction is used the replacement air is usually provided by dedicated ducting not shown here.

NOTE

The smoke extract header duct runs around the basement at high level often branching off in many directions. For clarity only one branch is shown here.

For details of system please refer to Types of Application.



DURASTEEL® Ducting Design Considerations

Enclosed Basement Car Parks (Mechanical Ventilation of Car Park)

A commercial development may have multiple level sub-surface or enclosed parking. This will require a mechanical ducting system to extract car exhaust fumes during normal usage via low level 'dropper' ducts and for the systems fan to increase its extract volume in fire conditions to exhaust smoke from the high level 'collector ducting'.

As an alternative to high level 'collector ducting', plenum ceilings may save space and avoid the costs of expensive civils construction, see [Plenum Ceiling page 70](#). Resistance to impact and moisture is beneficial for these vulnerable locations.

COMPONENTS

- The air extraction system ① should be rated at 300°C for 1 hour minimum. The fan is to be located in a 1-hour minimum fire compartment if the fan room is located within the building.
Ref: BS 5588: Part 9 (6.4.2)
- The protected shaft ② encloses the ductwork.
Ref: BS 5588: Part 9 (6.2.3)

- Penetration sealing ③ at compartment walls and floors is to be as used in fire testing of the duct system.
Ref: BS 476: Part 24
Ref: BS 5588: Part 9 (6.4.9)
- The duct system used within the protected shaft, plant room and basement car park areas may be upgraded with insulating material over escape routes ④ or adjacent to fire hazards, to provide full fire insulation to BS 476: Part 24.
Ref: BS 5588: Part 9 (6.4.3)
Ref: BS 5588: Part 9 (6.5.2)
- Low level 'dropper' ducts ⑤ and high level 'header' duct ⑥.

DESIGN PARAMETERS

- Fire dampers should not be provided in extract ducting serving car parks.
Ref: BS 5588: Part 9 (6.3.4.2)
- All system components are to have a minimum melting point of 800°C. No aluminium or fibre glass components.
- The system should provide 6 air changes per hour in normal operation. 10 air changes in fire conditions and be separated from any other ventilation system (other than any system providing normal ventilation to car park).

- Where the ductwork passes through fire resistant walls or floors the system must have been tested to BS 476: Part 24: 1987.
Ref: BS 5588: Part 9 (6.2.5.1)
- The system should provide smoke vents 50% at high level and 50% at low level.
- The system is to be designed to run in two parts, extracting 50% each part, being able to run together or separately.
- Each part to have an independent power supply which would operate in the event of a failure of the main power supply.
- The system must retain 75% of its cross sectional area to be suitable for smoke extraction purposes.
Ref: BS 476: Part 24

DURASTEEL® Ducting Design Considerations

Enclosed Basement Car Parks (Mechanical Ventilation of Car Park)

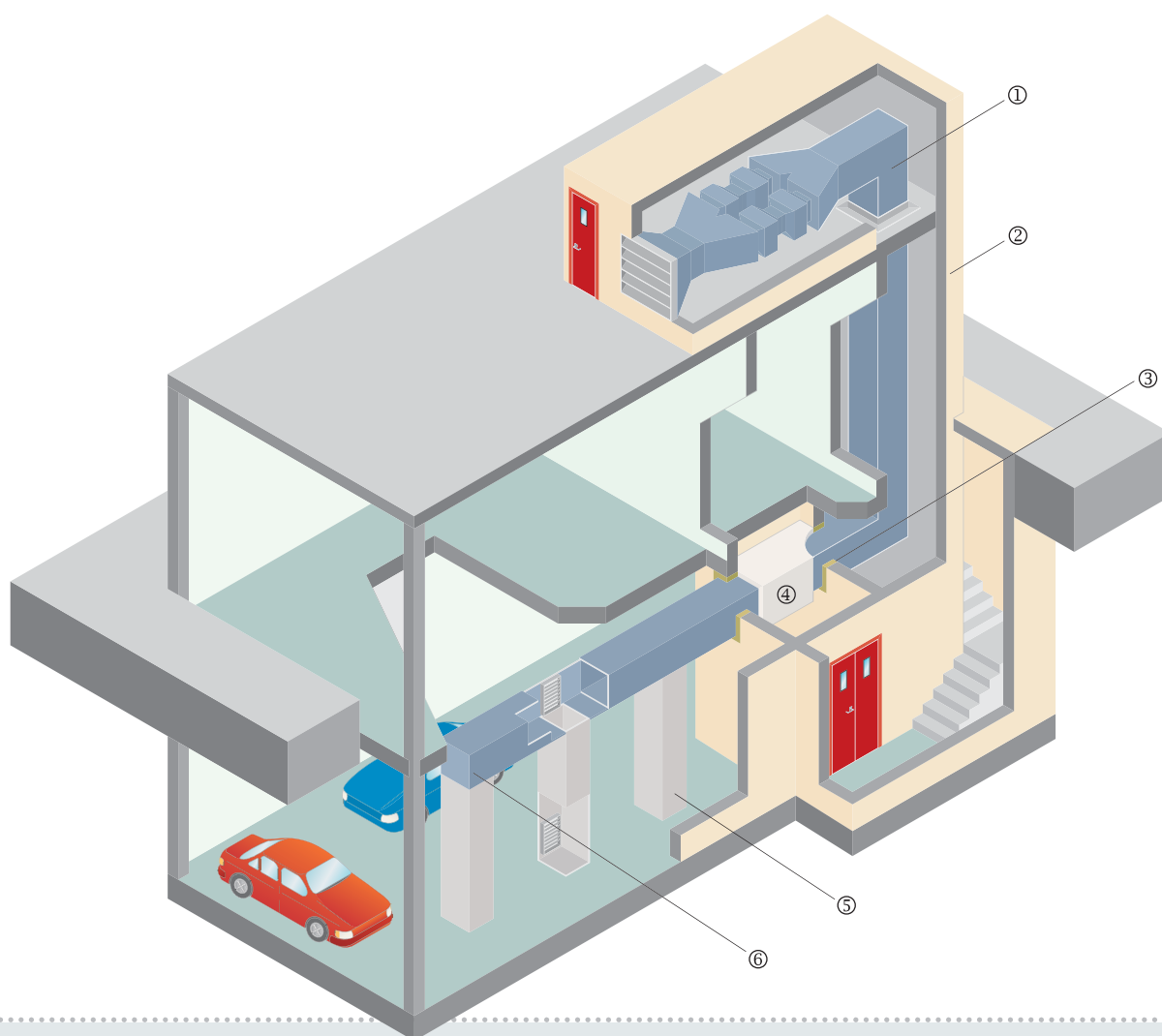

REFERENCE DOCUMENTS

- BS 476: Part 24: 1987.
- BS 5588: Part 9: 1999.

REPLACEMENT AIR

The replacement air is usually drawn down the entry ramp or may be provided by dedicated ducting.

NOTE

The high level collector ducting runs around the car park together with its 'dropper' ducts, it branches off in many directions. For clarity only one branch is shown here.

The fire load for car parks is well defined and not particularly high. Where a car park is well ventilated, there is a low probability of fire spread from one storey to another. Because of this, car parks are not normally expected to be fitted with sprinklers.

For details of system please refer to Types of Application.



DURASTEEL® Ducting Design Considerations

Non-domestic Kitchen Extract Ducting

The most likely cause of fire within the kitchen of any commercial development is the overheating of oils and fats used in frying. This may be caused by the failure of temperature monitoring equipment allowing the heated 'fuel' to reach ignition temperatures.

Poor housekeeping, lack of maintenance and careless working procedures together with the kitchen's design layout add further to the risk of fire.

The fire resisting ductwork serving the kitchen must be able to safely convey polluted air from the kitchen to atmosphere and also prevent an internal fire from spreading to other compartments. It must also have resistance against external fire in another compartment as this might otherwise deposit grease within the duct. In order for the kitchen extract system to function correctly, it is essential that provision is made for replacement air (not shown on adjacent drawing here).

COMPONENTS

- The air extraction system ① should be rated at 300°C for 1 hour minimum. The fan is to be located in a 1-hour minimum fire compartment if the fan room is located within the building.
Ref: BS 5588: Part 9 (6.4.2)
- The protected shaft ② provides compartmentation between the duct and other areas of the building. Other ducts located in close proximity to the kitchen extract duct within the shaft may require consideration for cross-over fires with regard to the duct insulation requirements.
Ref: BS 5588: Part 9 (6.2.3)
- Access panels ③ are fitted every three metres for cleaning purposes and at bend.
Ref: BS 5588: Part 9 (6.4.6.1)
- The kitchen exhaust system is often installed uninsulated within the protected shaft (without an insulating outer covering). It may be upgraded to insulated ④ over escape routes, within plant rooms or adjacent to potential fire hazards.
Ref: BS 5588: Part 9 (6.4.3)
Ref: BS 5588: Part 9 (6.5.2)
- Penetration sealing ⑤ at compartment walls or floors should be as used in fire testing of the duct system.
Ref: BS 476: Part 24
Ref: BS 5588: Part 9 (6.4.9)

DESIGN PARAMETERS

- Fire dampers should not be provided in extract ducting serving non-domestic kitchens.
Ref: BS 5588: Part 9 (6.3.4.2)
- Horizontal runs of ductwork should be limited to prevent grease build-up.
Ref: HVCA DW171 (14.9)
- A grease trap/sump is to be installed at 90° bends for draining purposes.
Ref: HVCA DW171 (14.19)
- Most kitchen extract ducts are located within a protected shaft. Where the duct exits this shaft and crosses other 'risk' areas. Care must be taken that the duct is protected from external fire to prevent ignition of grease inside the duct. Fire insulation of the duct in risk areas should meet the additional requirements described for kitchen extract ducts.
Ref: BS 476: Part 24 (Duct Type A additional requirements for kitchen extract ducts)
- The duct must also provide duct Type B fire resistance to BS 476: Part 24 in line with the kitchen compartment rating for extraction of smoke from a kitchen fire.
Ref: BS 476: Part 24 (Duct Type B)
- Ductwork carrying polluted air must have separate and independent extraction with no re-circulation.
Ref: BS 5588: Part 9 (6.4.6.1)
Ref: BS 5588: Part 9 (6.5.6.2)

DURASTEEL® Ducting Design Considerations

Non-domestic Kitchen Extract Ducting

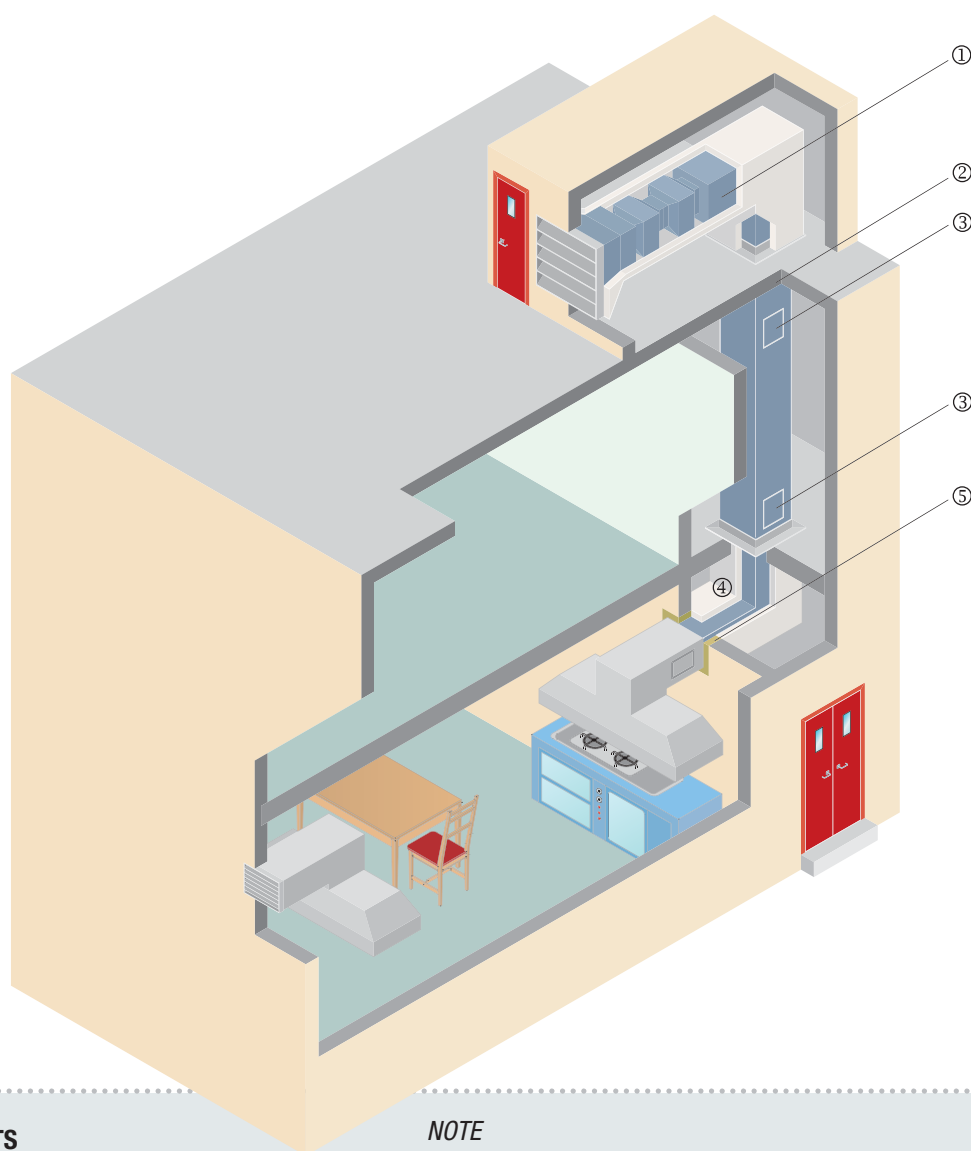

REFERENCE DOCUMENTS

- BS 476: Part 24: 1987.
- BS 5588: Part 9: 1999.
- HVCA DW171: 1999.

NOTE

DW171 (HVCA Guide for Kitchen Ventilation Systems) recommends that ductwork systems extracting from non-domestic kitchens are regularly cleaned. A fire suppression system may be required by the Building Regulations but is not shown here.

For details of system please refer to Types of Application. Prior to installation it is advisable to confirm the duct's insulation requirements throughout its route with the relevant authority.



DURASTEEL® Ducting Design Considerations

Smoke Extract Ducting For A Typical Commercial Building

A typical commercial development will have multiple levels/compartments requiring smoke extraction.

Provision of smoke extract ducting assists the safe evacuation of the building occupants whilst providing visibility in the fire compartment to aid the fire services in fighting the fire.

The main 'public' area on each floor will visually be designed as an individual fire compartment. The use of fire resisting/smoke extraction ducting systems within this compartment ensures that effective smoke extraction is carried out. When fire is detected, motorised smoke/fire dampers are operated by the building's fire control management system. On the non-fire floors these dampers are closed but remain open within the fire zone to enable smoke extraction from the area.

Additional supply air systems (not shown here) provide air into the non-fire zones to aid escape and to repel smoke. Supply air ducting is closed off within the fire zone. The use of smoke extraction ducting systems, together with the building's fire control management system, gives the fire services flexibility in fighting the fire.

COMPONENTS

- The air extraction system ① should be rated at 300°C for 1 hour minimum. The fan is to be located in a 1-hour minimum fire compartment if the fan room is located within the building.
- The protected shaft ② encloses the ductwork.
- Penetration sealing ③ at compartment walls and floors is to be as used in fire testing of the duct system.
Ref: BS 476: Part 24
- Motorised smoke/fire damper ④ controlled by the building's fire control management system.
- The duct system used within the protected shaft, plant room and basement car park areas may be upgraded with insulating material over escape routes ⑤ or adjacent to fire hazards, to provide full fire insulation to BS 476: Part 24.
- Steel run-out ducting ⑥ is used for extracting smoke. Connected to grilles and feeding smoke and hot gases into the main smoke extract ducting.
Ref: BS 476: Part 24

DESIGN PARAMETERS

- Must be capable of extracting smoke and partly combusted gases from the building and discharging them to atmosphere.
- Where the ductwork passes through fire resistant walls or floors the system must have been tested to BS 476: Part 24: 1987.
- The system must retain 75% of its cross sectional area to be suitable for smoke extraction purposes.
Ref: BS 476: Part 24

GENERAL COMMENT

In line ancillary equipment such as attenuators, volume control dampers etc must be fire resistant to the same standard as the fire resisting ductwork. These items are normally encased in fire resistant materials and suspended on drop rods installed to the same loading requirements used for the fire resisting ductwork.

REFERENCE DOCUMENTS

- BS 476: Part 24: 1987.

NOTE

Supply air ductwork is not shown here.

A sprinkler system may be required by the Building Regulations but is also not shown here.

For details of system please refer to Types of Application.



DURASTEEL® Ducting Design Considerations

Smoke Extract Ducting For A Typical Commercial Building

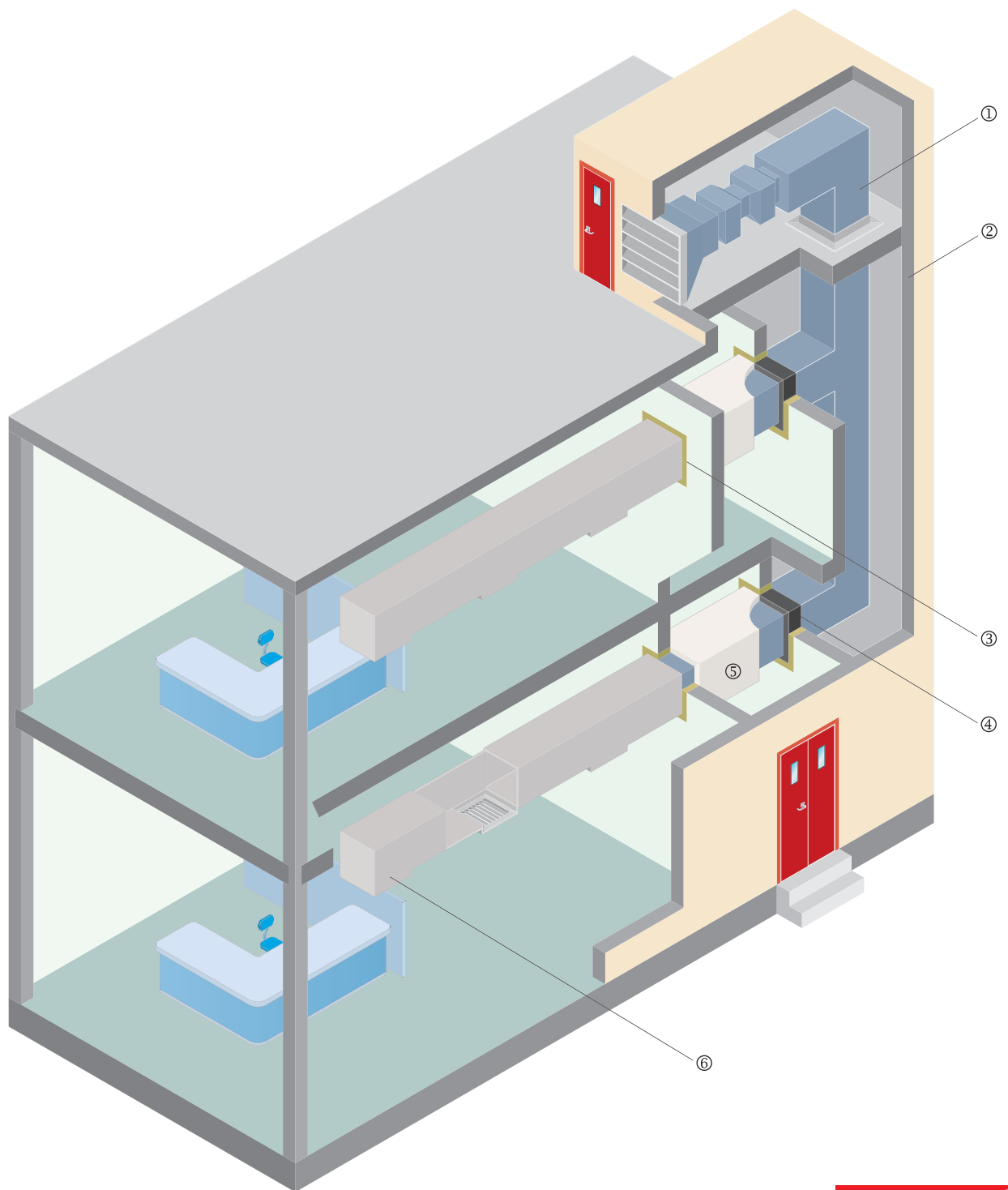



DURASTEEL® Ducting Design Considerations

Dual Purpose Ventilation/Smoke Extract Ducting

Dual purpose systems are designed to provide conditioned air into the building during normal operation and to extract smoke in the case of fire.

The conditioned air may require the ducting to be thermally lagged to maintain its temperature. It is vital that this lagging is made of a non-combustible non-toxic material due to its role as a smoke extract ducting.

These types of 'dual purpose' systems may be a more economical solution when compared to providing dedicated smoke extract systems.

In a fire, the building's fire control management system operates to reverse the fans and separates the duct from its conditioning function via change over dampers.

The fan's extract volume increases to pull the smoke from the fire compartment.

COMPONENTS

- The air extraction system ① should be rated at 300°C for 1 hour minimum. The fan is to be located in a 1-hour minimum fire compartment if the fan room is located within the building. The change over dampers ② switch the system from supply to extract.
- The protected shaft ③ encloses the ductwork.
- Penetration sealing ④ at compartment walls or floors is to be as used in fire testing of the duct system.
Ref: BS 476: Part 24
- Motorised smoke/fire damper ⑤ operated via the building's fire control management system.
- The supply/extract system may be upgraded with insulating material ⑥ over escape routes or adjacent to fire hazards, providing full fire insulation to BS 476: Part 24 (Duct Type B).
- Steel run-out ducting systems ⑦ are used for extracting smoke. Connected to grilles and feeding smoke and hot gases into the main smoke extract ducting.

DESIGN PARAMETERS

- Must be capable of extracting smoke and partly combusted gases through the building and discharging them to atmosphere.
- Where the ductwork passes through fire resistant walls or floors the system must have been tested to BS 476: Part 24: 1987.
- The system must retain 75% of its cross sectional area to be suitable for smoke extraction purposes.
Ref: BS 476: Part 24
- Ancillary equipment such as attenuators volume control dampers etc must be fire resistant to the same standard as the fire resisting ductwork. These items are normally encased in fire resistant materials and suspended on drop rods installed to the same loading requirements used for the fire resisting ductwork.
- Care should be taken when selecting any thermal lagging that may be required for dual purpose ventilation/smoke extract ducting, with regard to combustibility.

REFERENCE DOCUMENTS

- BS 476: Part 24: 1987.

NOTE

Supply air ductwork is not shown here.

A sprinkler system may be required by the Building Regulations but is also not shown here.

For details of system please refer to Types of Application.



DURASTEEL® Ducting Design Considerations

Dual Purpose Ventilation/Smoke Extract Ducting

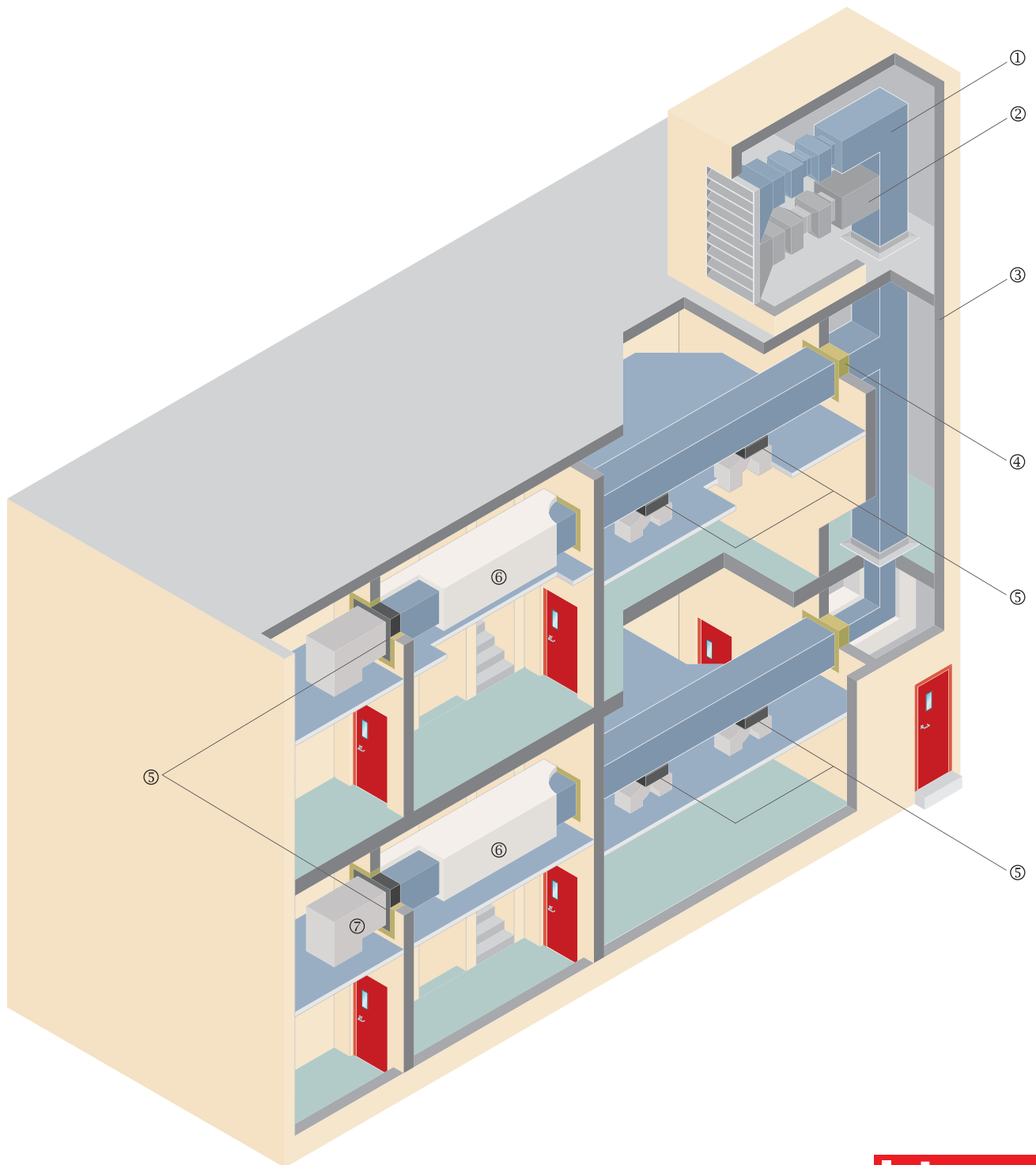

DURASTEEL® Ducting Design Considerations

Pressurisation Ductwork

Most types of commercial developments will require the provision of escape stairways and corridors and may require fire fighting shafts. To ensure the supply of fresh air to these vital areas during fire, pressurisation ductwork may be installed within the protected space or inside protected shafts routed through the building.

Where the ductwork runs through a fire compartment, fire resistant ductwork should be used. The pressurised air inhibits the penetration of smoke into the protected areas providing 'safe havens' for evacuation or for fire fighting access.

Fire dampers should not be used in pressurisation systems.

COMPONENTS

- The pressure differential equipment i.e. fan, motor or control gear ① should be housed:
 - a) in an enclosure with a fire resistance of not less than 60 minutes, preferably in a plant room separated from other plant on or near the ground level and close to the air supply intakes; or
 - b) at the roof level if the fire resistance separation between the plant room and the building below is not less than 60 minutes within 5 metres measured horizontally of any part of the pressure differential system equipment or enclosure.

Access doors to the enclosure should have a fire resistance of not less than 60 minutes and be self-closing.

Note: Where the pressure differential system protects a fire fighting shaft the level of fire resistance should be increased to 120 minutes.

- Smoke control dampers ②.
.....
- The protected shaft ③ encloses the ductwork.
Ref: BS 5588: Part 9 (6.2.3)
.....
- Penetration seals ④ at compartment walls or floors are to be as installed as used in fire testing of the duct system.
Ref: BS 476: Part 24
Ref: BS 5588: Part 9 (6.4.9)
.....
- Supply ducting ⑤.
.....
- Supply ducting ⑥ that penetrates a fire resisting compartment should be protected using the methods given in BS 5588: Part 9: 1999.
Ref: BS 5588: Part 4 (11.1)
Ref: BS 5588: Part 9 (6.2)
.....
- Steel ducting ⑦ may be used for supplying air to the lobbies (for example).
.....
- Fire fighting lift ⑧.
.....

DESIGN PARAMETERS

- Fire dampers should not be used in pressurisation ductwork.
Ref: BS 5588: Part 4 (11.1)
.....
- The system must have been tested as Duct Type A to BS 476: Part 24: 1987.
Ref: BS 5588: Part 9 (6.2.5)
.....
- Air intake positions are where possible to be located on or near ground level. They should not be located near to potential fire hazards or in close proximity to basement smoke vent discharge points.
Ref: BS 5588: Part 4 (11.1)
.....
- If located at roof level air intake must be taken from two sources located to face in different directions. Each inlet must be capable of providing the full air requirements of the system. Each inlet should be protected by an independently operated smoke control damper ② in such a way that if one damper closes due to smoke contamination, the other inlet will continue to supply the air requirements for the system.
Ref: BS 5588: Part 4 (11.1)
.....

REFERENCE DOCUMENTS

- *BS 476: Part 24: 1987.*
.....
- *BS 5588: Part 4: 1998.*
.....
- *BS 5588: Part 9: 1999.*
.....



DURASTEEL® Ducting Design Considerations

Pressurisation Ductwork

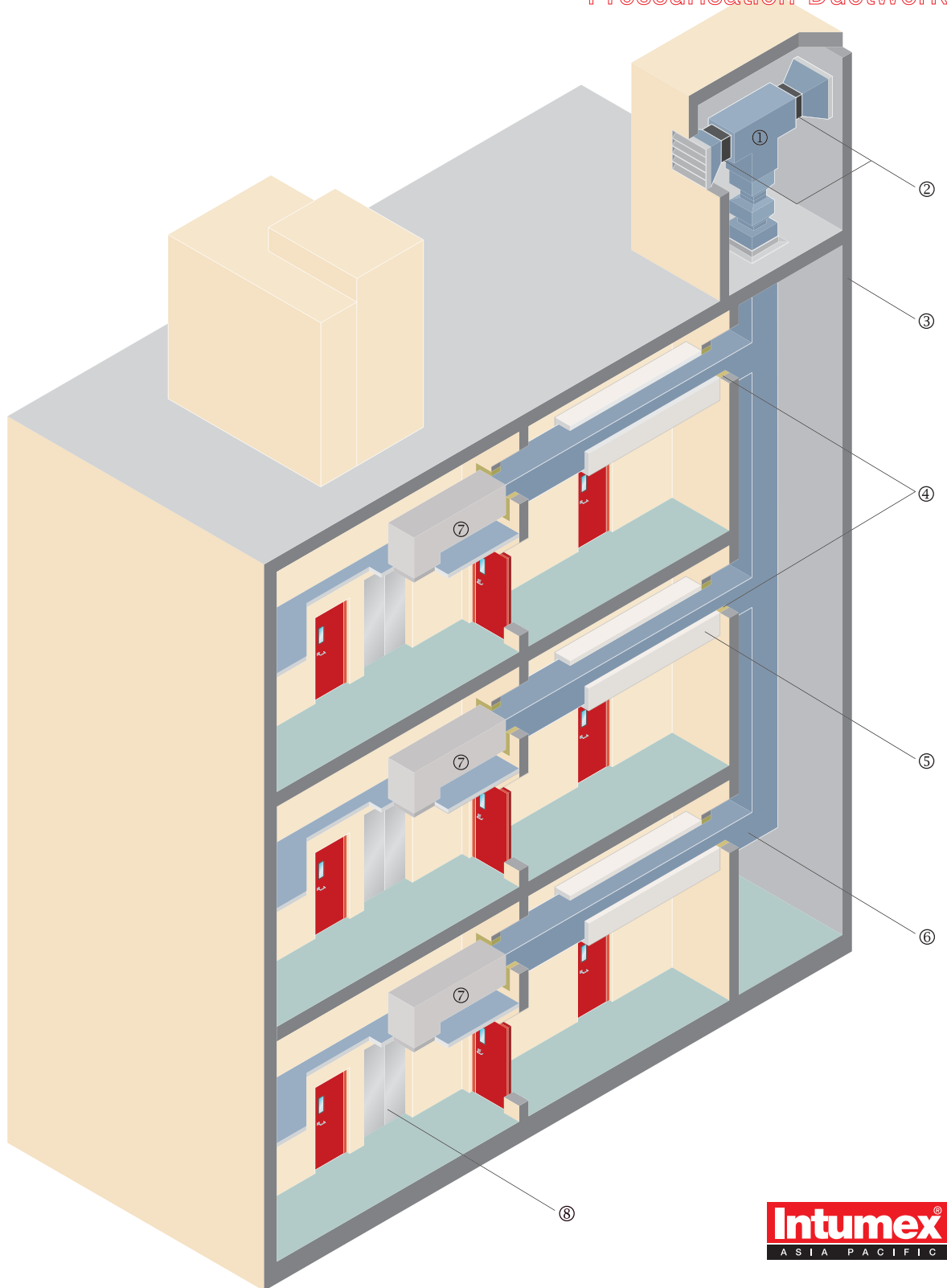



DURASTEEL® Ducting Design Considerations

Transformer Electrical Room Inlet & Extract Ducting For A Sub-surface Chamber

A typical major office or retail development will have transformer and electrical rooms to provide additional power requirements and to ensure control of emergency apparatus. If these are located sub-surface and cannot be naturally vented they will require mechanical smoke extraction.

This graphic identifies the use of DURASTEEL® ducting systems and other DURASTEEL® applications that are commonly specified to provide the necessary fire and blast protection. Intumex Asia Pacific is able to provide a 'one stop shop' solution for transformer/electrical room fire protection.

COMPONENTS

• Fire Resistant Ducting ① & ②

DURASTEEL® natural ventilation and mechanical ducting systems are the perfect solution to be supply ③ and exhaust venting ④ of transformer and switchgear rooms due to the material's proven performance in resisting extremes of pressure.

Transformers may explode upon failure and the extreme pressure build-up from its explosion is contained by the chamber itself and is vented out to atmosphere via the chamber's ductwork. This extreme of pressure can cause the collapse of sheet steel duct systems resulting in a failure to extract and contain toxic smoke.

Emergency generators need a steady supply of fresh air to ensure operation in fire conditions; DURASTEEL® supply ductwork remains intact following the blast and provides this essential ventilation.

• Penetration Seals ⑤

The fire sealing penetration sea around the ductwork should be installed as tested to BS 476: Part 24, in the case of DURASTEEL® systems this is with DURASTOP Original. This sealant is extensively tested and is used in power station applications in countries around the world. Often, DURASTOP Original is used together with DURASTEEL® sheet to seal openings around building services in fire compartment walls and floors. These panels may be demountable for future access.

• Blast/Fire Resisting Ceilings ⑥

The chamber may require the insulation of a DURASTEEL® blast ceiling to improve the performance of existing structures. This blast barrier prevents debris from an exploding transformer penetrating occupied areas above. Each barrier is purposely designed to suit the individual location.

• Demountable Fire Barriers

Fully demountable DURASTEEL® barriers allow for access to the chamber to replace equipment. Alternatively, loadbearing floor panels or trap doors located in the floor above the chamber may be used. Fire resistance periods of 60 to 240 minutes integrity and insulation are available.

• Cable Enclosures ⑦

Cables entering/leaving the chamber may be protected in DURASTEEL® demountable enclosures. These may be installed in stages to suit the building programme. The support system can be designed to carry the weight of ladder racks, cable trays etc. Cables may be separated by the installation of DURASTEEL® splitters.

• Steel Doors ⑧

Fitting a DURAFIRE door to the chamber completes the compartmentation. These steel doors provide security to the chamber especially in remote locations. Louvres providing airflow to the chamber can be fitted to the door leaf where specified. These may be dampered to shut down in fire conditions. Overhead or side panels can be fitted together with demountable transoms to allow the complete assembly to be removed for removal of equipment.

Man sized access hatches with 'gas struts' are available to individual design and floor mounted plant room access doors for equipment removal can be supplied.

DURASTEEL® Ducting Design Considerations

Transformer Electrical Room Inlet & Extract Ducting For A Sub-surface Chamber

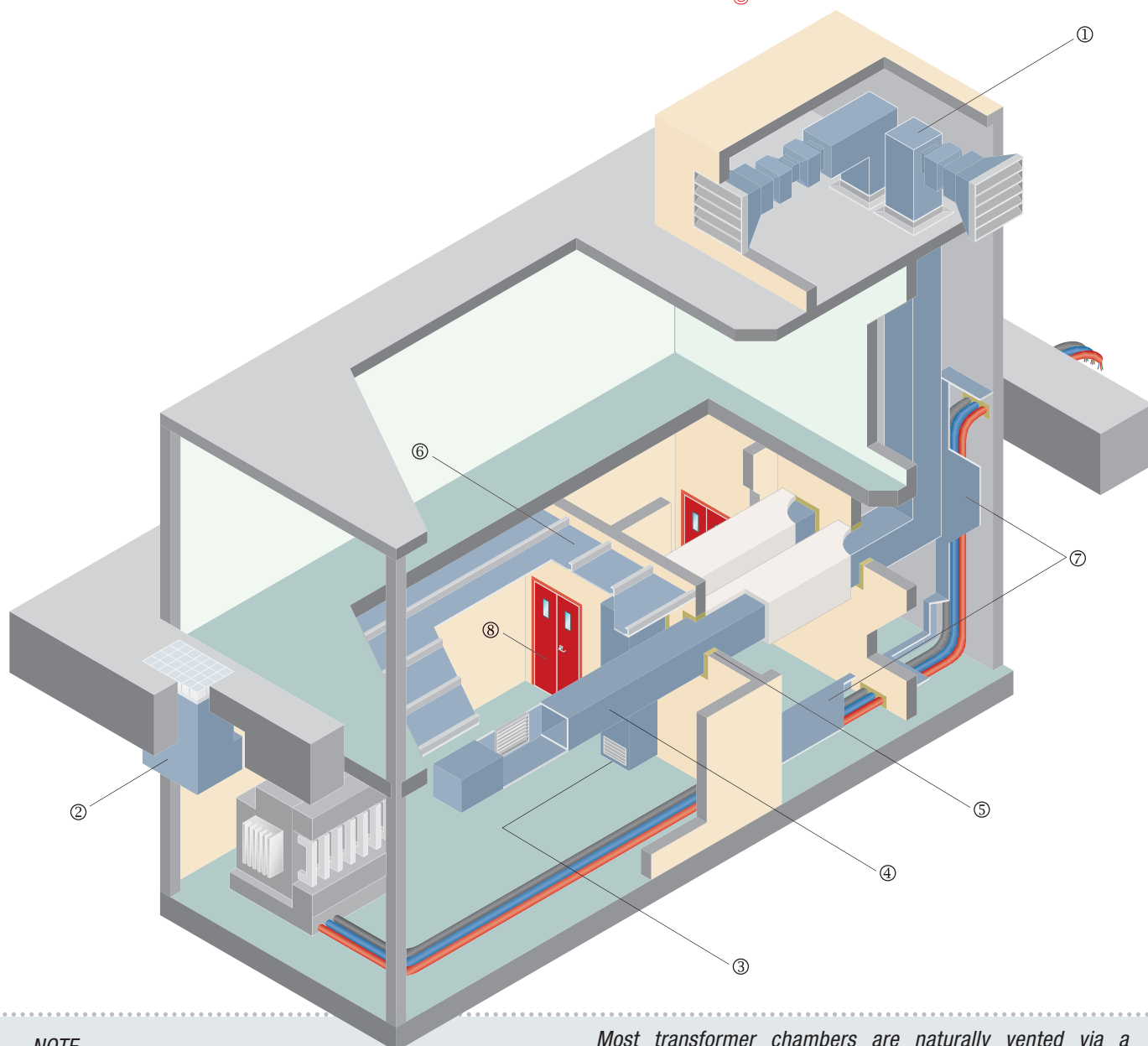

NOTE

For details of system please refer to Types of Application on page 52~58. For further information regarding DURASTEEL® Doors please refer to page 73~87.

A fire compression system may be required by the Building Regulations but is not shown on drawing here.

Most transformer chambers are naturally vented via a combination of civils construction and DURASTEEL® shafts/bulkheads ②.

Natural systems have no complicated components to fail during the vital period of time when smoke must be extracted from the building. Additionally, the risk of damage to components by any potential blast is removed.



DURASTEEL® Ducting Types of Application

DURADUCT SMT System



This system is constructed by the fabrication of a steel frame, which is encased in a single layer of DURASTEEL®. The DURASTEEL® thickness will be either 9.5mm for fire resistance periods of up to 240 minutes, or 6mm for fire resistance periods up to 120 minutes in terms of the stability and integrity criterion of BS 467: Part 24: 1987.

This system can be adapted to provide the insulation criteria by the inclusion of varying thickness and/or density of mineral wool. Please consult Intumex Asia Pacific for details.

The dimensions of the steel angles forming the flanges will be determined by the fire resistance, the dimensions of the duct itself, and the air pressure within the duct.

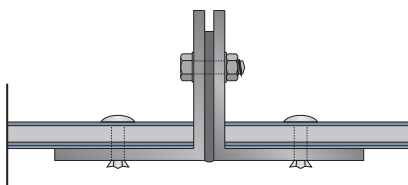

Where boards are joined in positions where flanges are not appropriate, or for the construction of small dimension ducts where flanges are not a necessity, a steel flat bar, minimum 100mm x 3mm can be used to form the joint.

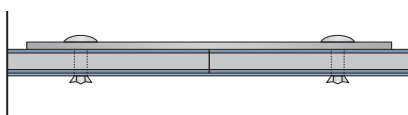

The DURASTEEL® material is fixed to the frame using self-drilling screws at nominal 200 mm centres, bedded onto a bead of Intumex Fire Resistant Acrylic Mastic. For use in wet areas, the use of Intumex Fire Resistant Silicone Mastic is recommended.

A DURASTEEL® SMT duct system can incorporate all the elements one would usually wish to see in a standard duct system. These are shown in the drawing on opposite page and components as follows.

- ① Access panels to facilitate cleaning the interior of the duct, or to allow maintenance access to dampers etc.
- ② Simple joining of sections using either steel angle flanges or the propriety flanges shown in Durasteel® LT sections.
- ③ Hanger support system. Standard hanger components can be used, the only criteria being that for support systems not insulated against fire, specific stress levels should not be exceeded. Please consult Intumex Asia Pacific for assistance with the design of hangers systems.
- ④ Interior of the duct can be of either plain DURASTEEL® sheet, which in itself has a friction resistance no different to that of standard galvanised steel, or can be lined, as in DURASTEEL® LT system, with a galvanised sheet to provide a easy clean surface ideal for kitchen extract or clean room duct systems.
- ⑤ Air grilles etc can easily be incorporated within the system.
- ⑥ All joints easily sealed using Intumex Sealants to ensure maximum air flow characteristics and leakage rates are well within the requirements of DW 144.
- ⑦ Angled corners or the construction of transformation sections to ensure smooth air flow with minimal turbulence within the duct.
- ⑧ A full system with superb impact resistance and other mechanical properties.



DURASTEEL® Ducting Types of Application

DURADUCT SMT System

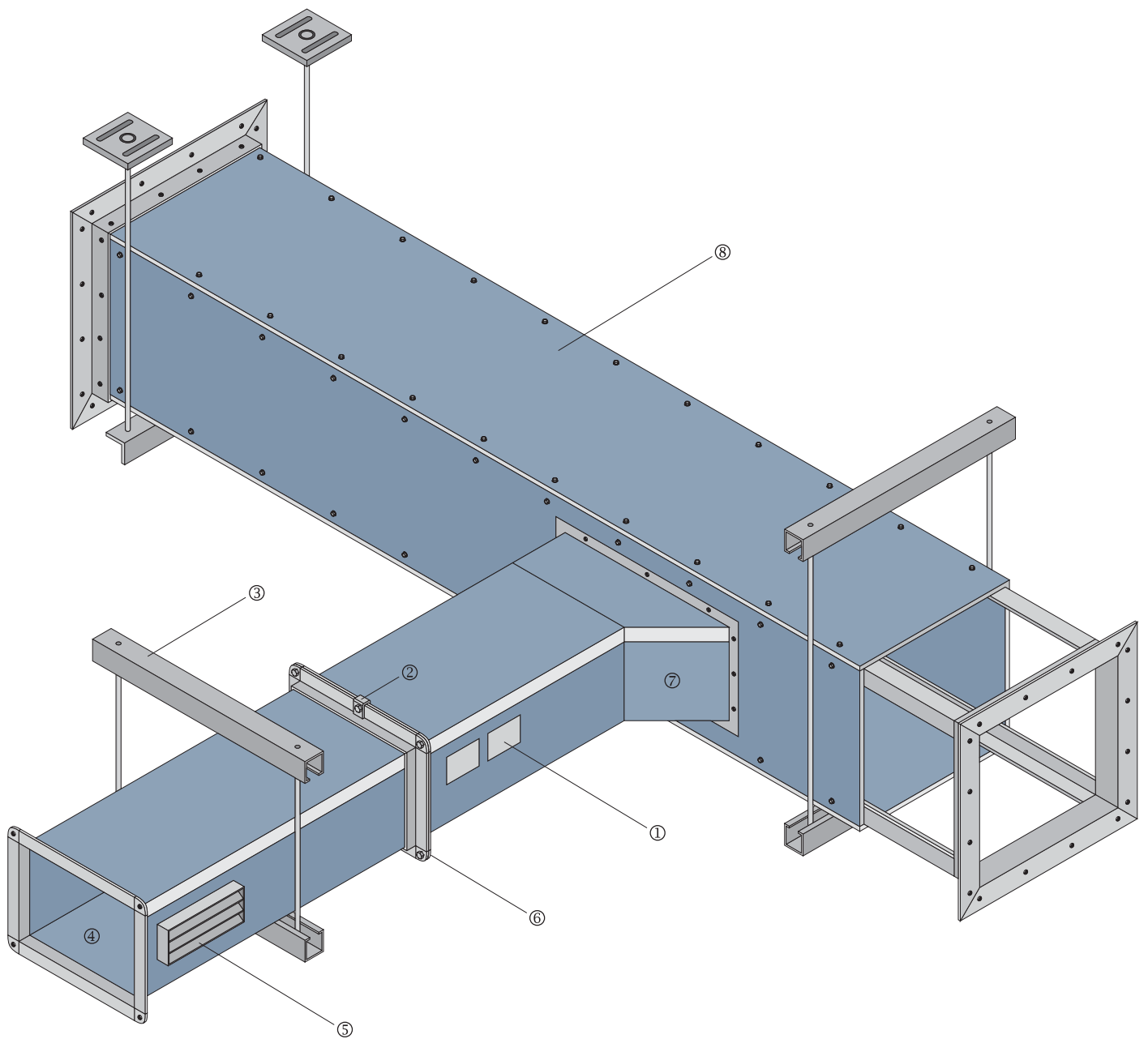



DURASTEEL® Ducting Types of Application

DURADUCT SMT Insulated System



The construction of the DURADUCT SMT insulated system is similar to the DURADUCT SMT system, with the addition of an external covering of mineral wool. This over cladding can perform a number of functions, two of which are:

- Where used as an air conditioning system, provides insulation to prevent condensation.
- Under fire conditions, ensures the system meets the insulation criteria appropriate to BS 476: Part 24: 1987.

- ① The steel support system will vary depending on the fire resistance and the size and weight of the ductwork. No additional fire protection to the support system is required if the correct design is used. Please consult Intumex Asia Pacific for details.
- ② Any duct system tested, has a specific design of penetration seal, this is tested as part of the duct system and in all instances, the installation of the penetration seal forms part of the ductwork installation. Please consult Intumex Asia Pacific for details.
- ③ DURASTEEL® duct with high impact and mechanical resistance.
- ④ Internal steel angle framing sections, dimensions dependant on the size and fire resistance of the duct.
- ⑤ Flange system, steel angles or DURADUCT LT propriety flange system.
- ⑥ Mineral wool, thickness and density dependent on the fire resistance and operating condition performance requirements.
- ⑦ Mineral wool fixing system, type of fixings depend on whether insulation has to function under ambient conditions only, or fire AND ambient conditions.



DURASTEEL® Ducting Types of Application

DURADUCT SMT Insulated System

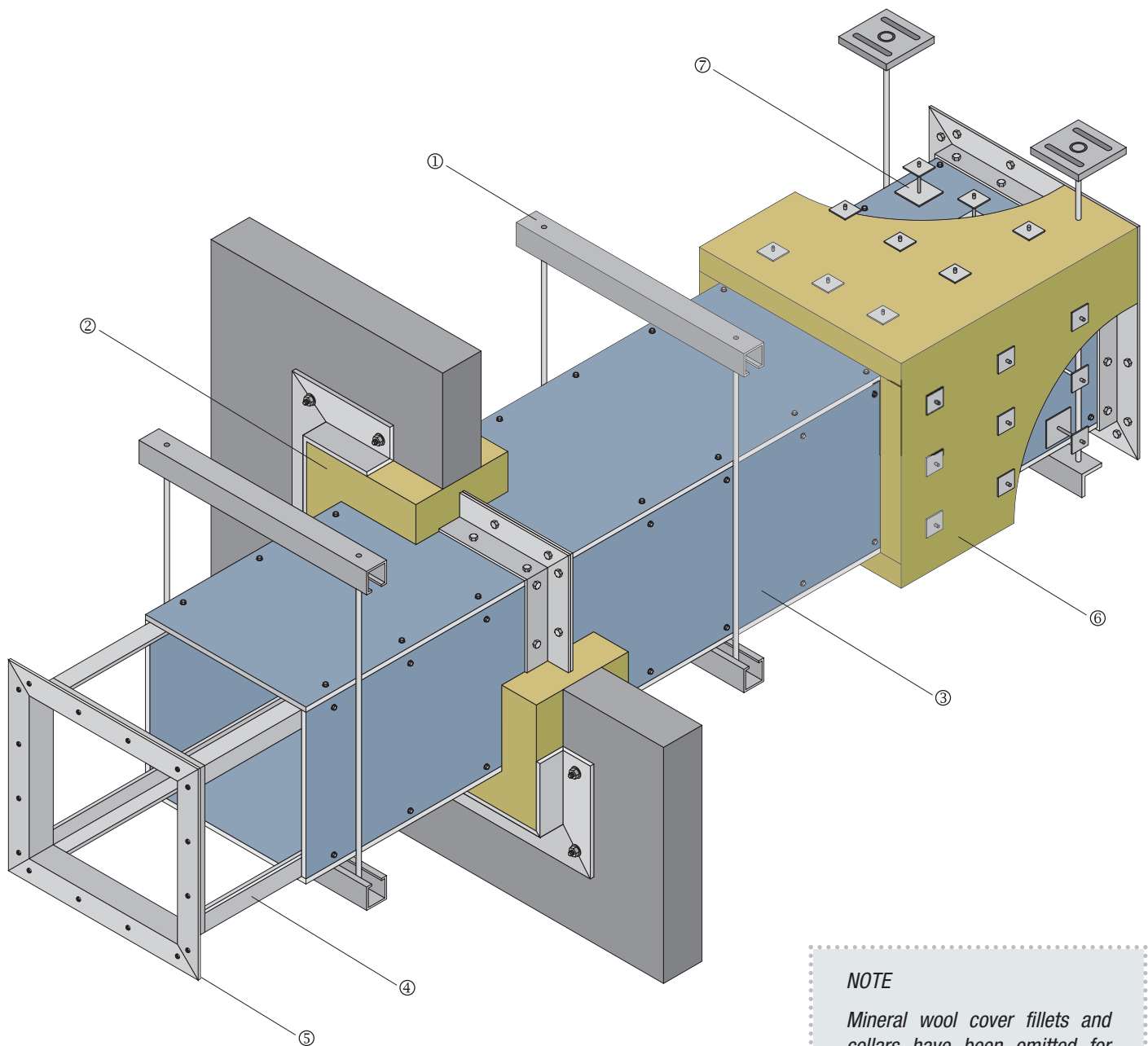

NOTE

Mineral wool cover fillets and collars have been omitted for clarity. If used as a kitchen extract duct, an internal steel liner is recommended for ease of cleaning.



DURASTEEL® Ducting Types of Application

DURADUCT LT System

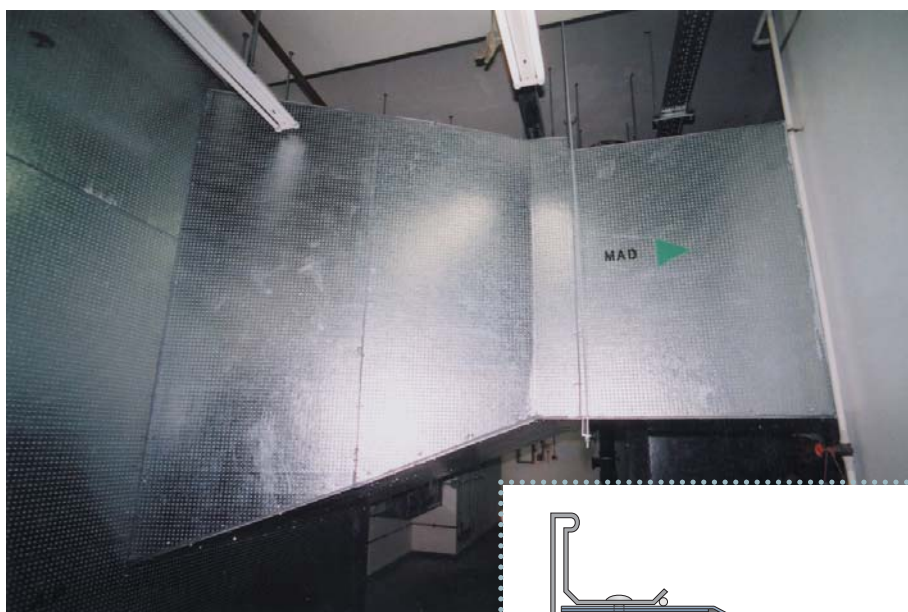

Detail below depicts proprietary flange system for Duraduct LT system. DURASTEEL® slips into flange and fixed into position. Flanges joined by caps and bolts.

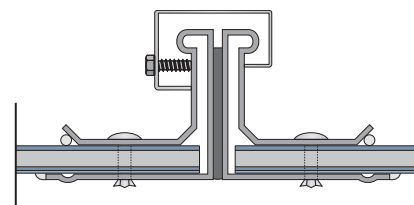

Section showing section end flange in greater detail is as on the left.

Note that for angled sections, joints should be backed using steel plate, folded to correct angle, minimum 50mm overlap.

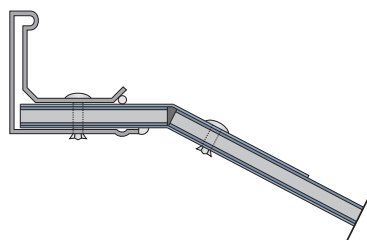

DURADUCT LT is a fast track and economical DURASTEEL® based fire resisting ductwork solution which combines airflow and easy cleaning characteristics of standard galvanised steel ductwork with the armour plated comfort of FIT & FORGET DURASTEEL®. DURADUCT LT is a tried and tested ductwork solution suitable for natural or mechanical ventilation, smoke vents, pressurisation ductwork and kitchen extract ducts.

The DURADUCT system can offer up to 240 minutes fire resistance in terms of both integrity and insulation criteria of BS 476: Part 24: 1987, depending on the system components.

DURADUCT consists of a duct constructed using 6mm DURASTEEL® boards with finishing trim angles. The system is installed using a propriety flange system. The inside is lined with a galvanised steel sheet. The total system thickness is approximately 7.5mm.

The following system detail shows propriety flanges at each opening of the duct, ready for connection to adjacent sections, with external trimming angles to ensure neat finish and airtight construction.

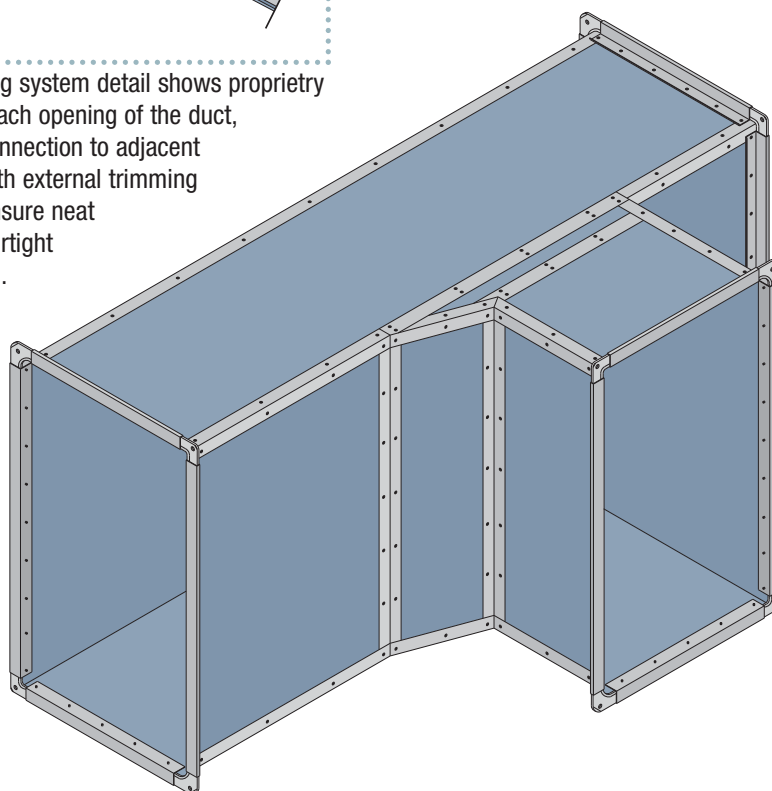

DURASTEEL® Ducting Types of Application

DURADUCT LT System

When constructing wide ducts, it may be necessary to provide stiffeners to ensure a minimum of 75% of the cross sectional area is maintained under fire conditions. This is of particular importance for smoke extraction systems. Please consult Intumex Asia Pacific for precise construction details.

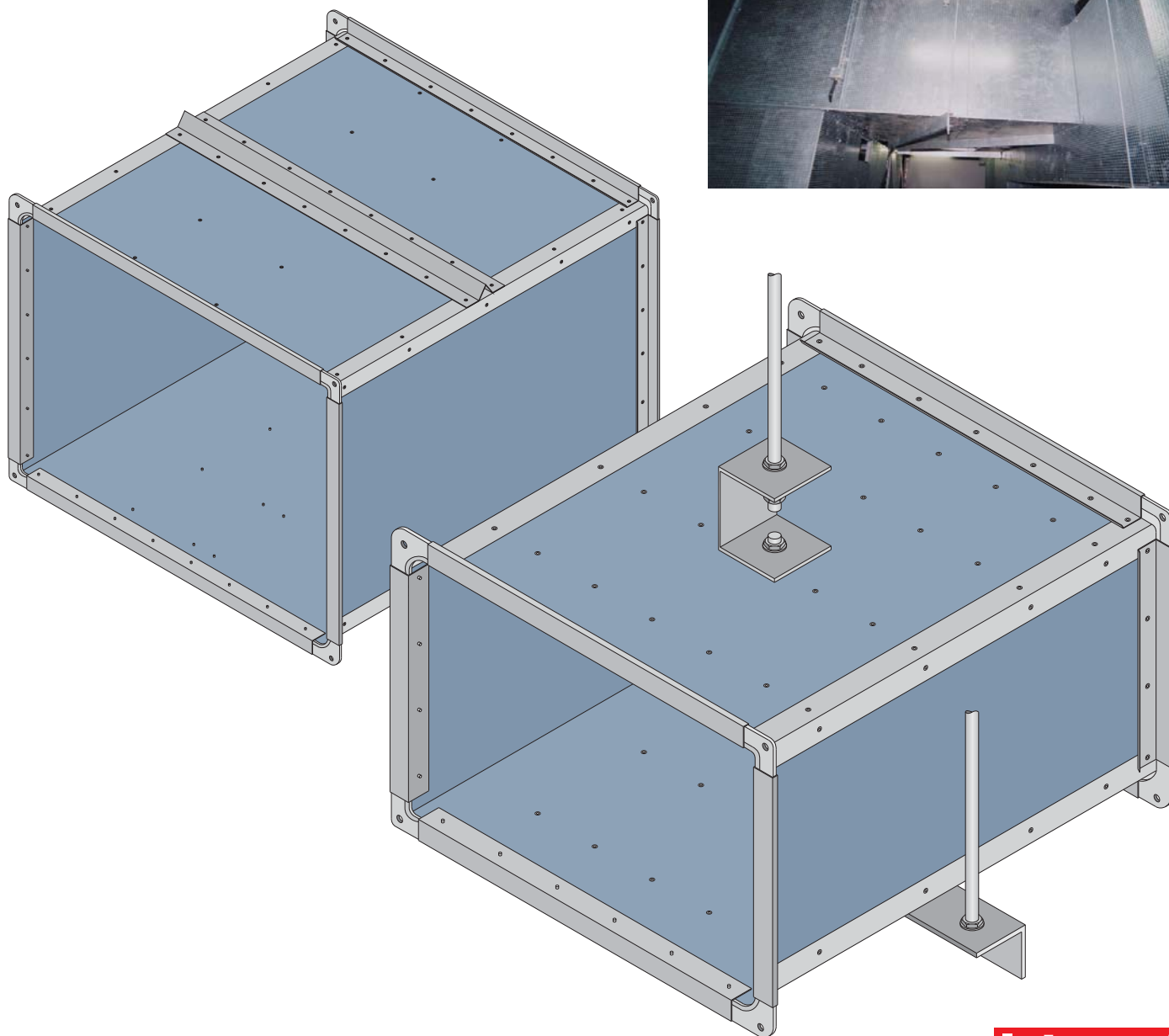



DURASTEEL® Ducting Types of Application

Vertical Ducts

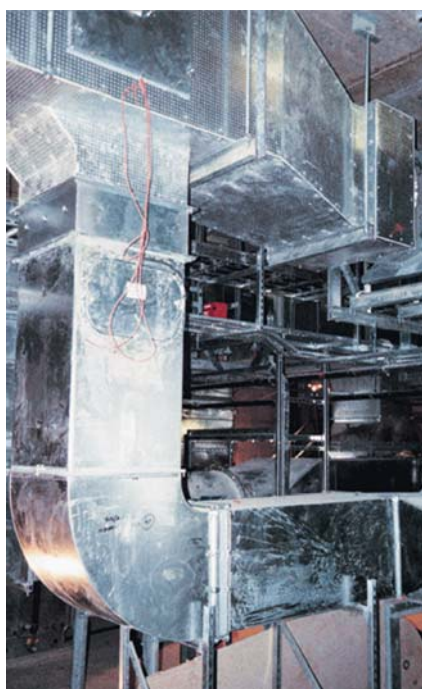

Both DURADUCT SMT and DURADUCT LT systems for all fire performance requirements can be installed in a vertical orientation.

Support for vertical ducts can be at floor slab levels, or for large ducts and/or long distances between slabs, support brackets can be cantilevered from the vertical structure of the building as detailed here.

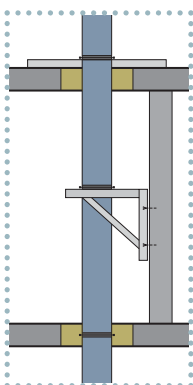

Detail right depicting cantilevered support framing.

Detail below depicting support from floor slab.

Dimensions and type of support framing depend on the fire resistance performance, the size and weight of the ductwork being supported, minimum unprotected support system stress levels.

Please consult your local Intumex Asia Pacific office for design details.

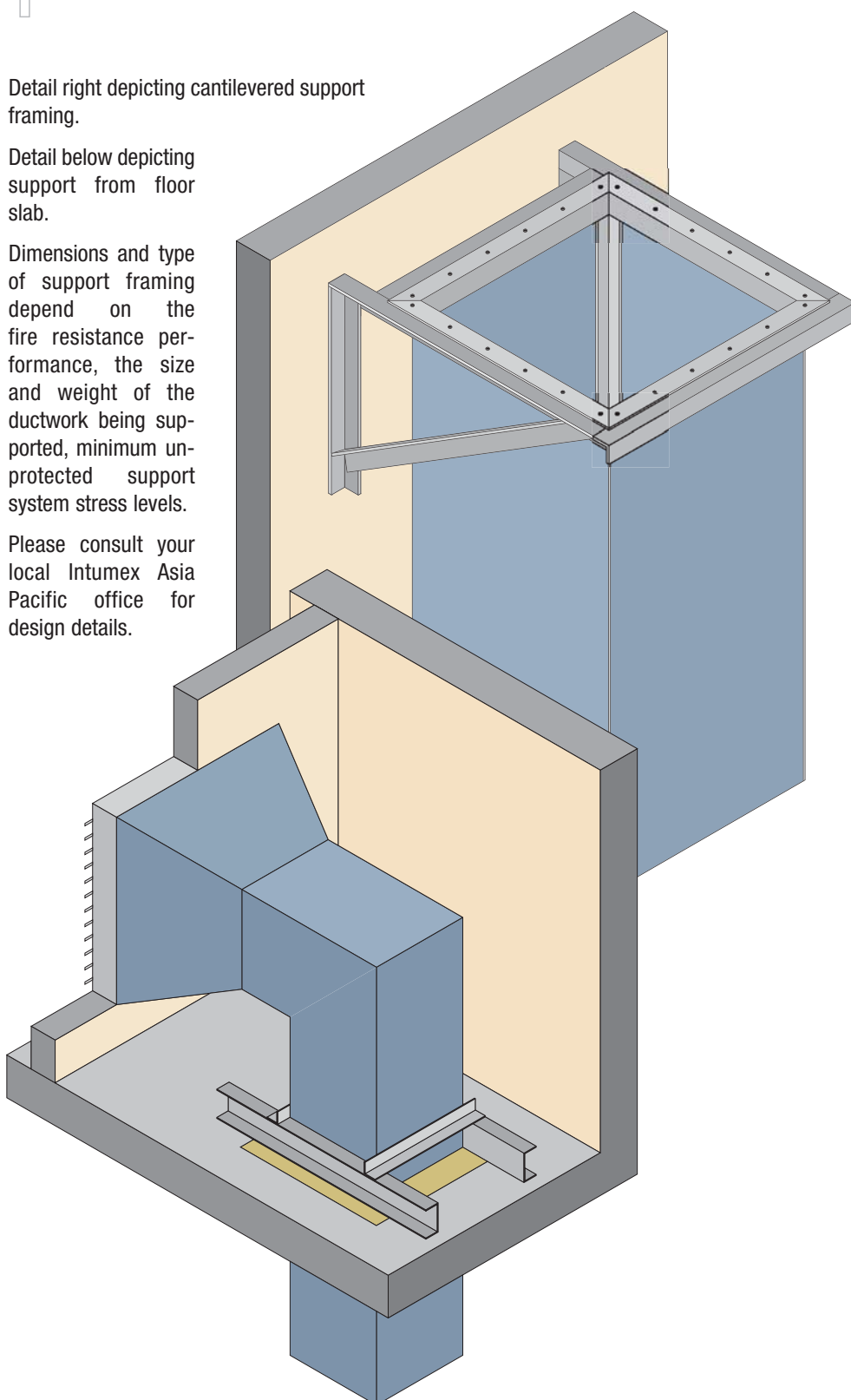

DURASTEEL® Ducting Construction Details

Variations Allowing Adaptability In Construction

Ducting may be constructed in 2, 3 or 4-sided versions. This versatility can save space, programme time and material cost when applicable. Care must be taken if the building structure is intended to maintain pressure as part of the ductwork system. In addition, any structure to which the DURASTEEL® system is affixed must have a fire resistance at least equal to that of the duct system itself.

- Single sided application no hanger support.

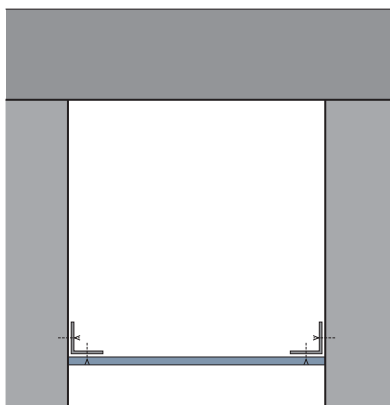

- 3-sided application using structure soffit as 4th side.

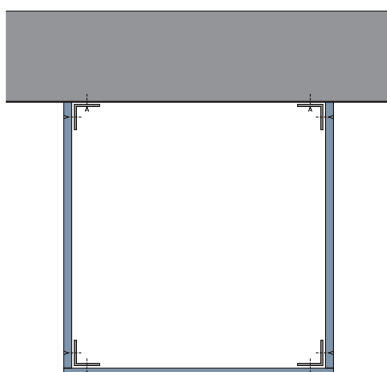

- 2-sided application using structure soffit as other two sides.

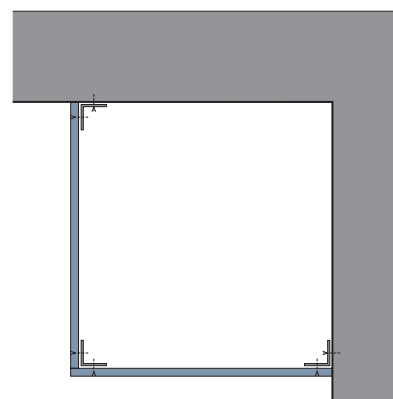

- 4-sided application using drop rods and cradle angle support.

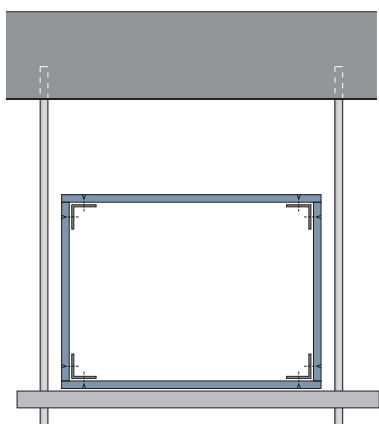

- 4-sided large duct, with stiffeners to ensure cross section of duct is maintained.

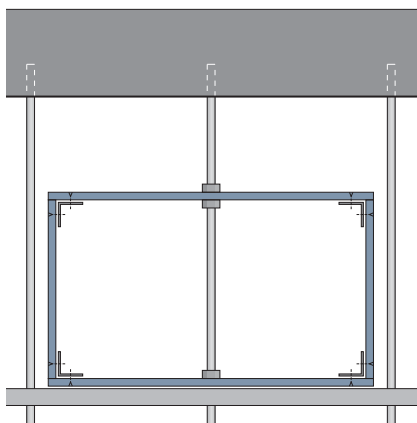

- Single sided application using central hanger support.

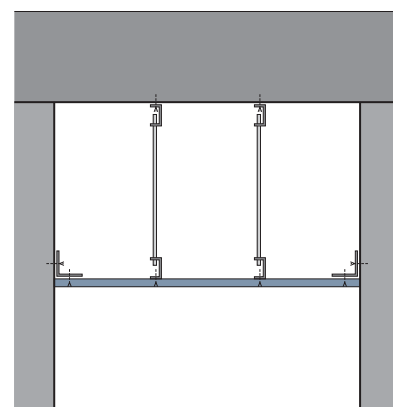

DURASTEEL® Ducting Construction Details

Single membranes installed across short spans can form plenum chambers or offer protection to other services. Larger spans are installed on a support system comprising of steel 'drop rods'. Flexible joints are available to span building movement lines.

Self-Supporting Plenum Ceiling

The suspended plenum ceiling detailed on the right is self-supporting. The structure ④ must have a fire performance at least equal to the plenum itself, the DURASTEEL® sheets ① will be either 6mm or 9.5mm dependant on fire performance requirements. The perimeter angle ③ is bolted to the structure using non combustible expansion bolts at nominal 600mm centres, the framing section ② dimension depend on the span of the plenum and the operating pressure it is to withstand.

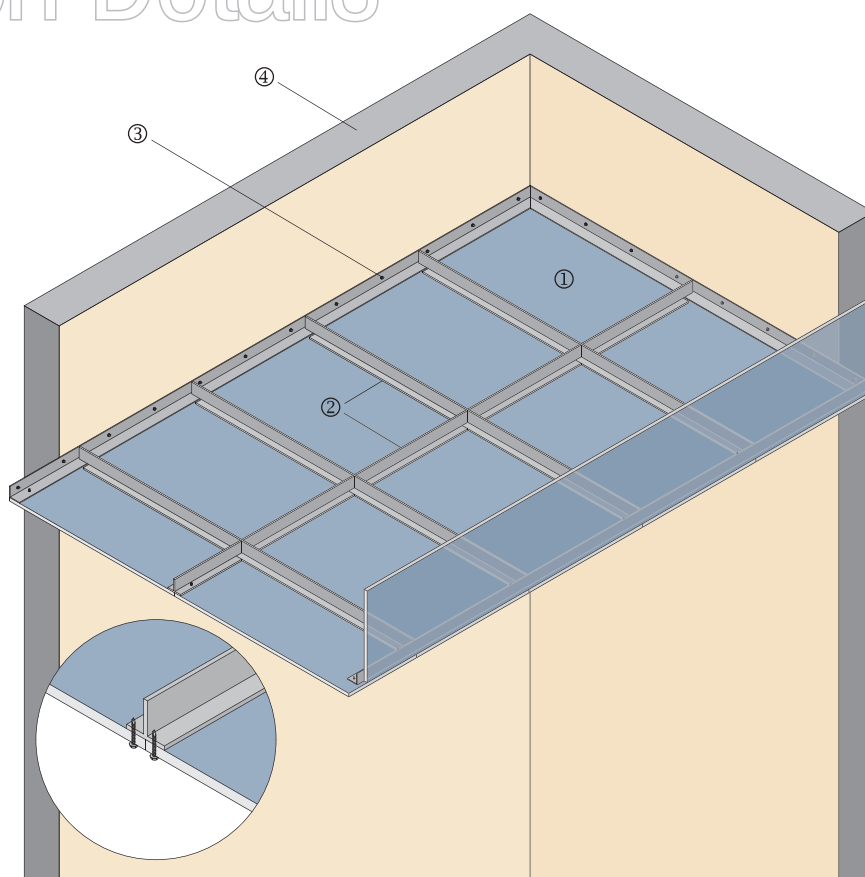

Suspended Plenum Ceiling

For wide spans, it may be more economical to use a ceiling plenum with hanger supports rather than increase steel section dimensions beyond practical limits. The steel section sizes ③ can be minimised using this method, provided the hanger support system ② is adequate and does not exceed permitted stress levels for unprotected sections. Please consult Intumex Asia Pacific for details. The DURASTEEL® ① is fixed to the framework in the normal fashion.

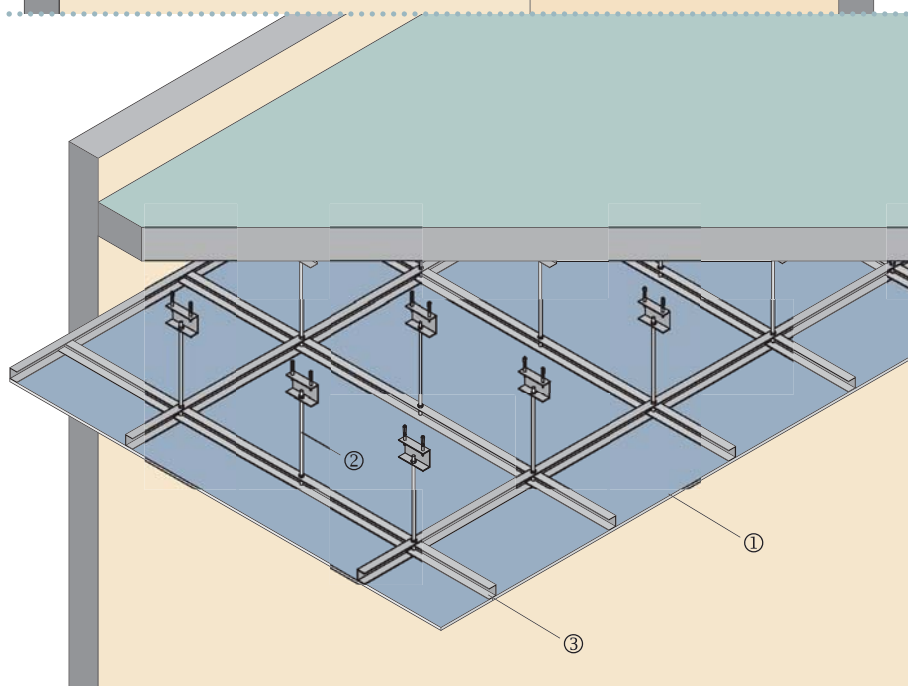

DURASTEEL® Ducting Construction Details

Installation of Ancillary Items

All types of typical ductwork ancillary items can be installed within DURASTEEL® ductwork systems without impairing the fire performance of the systems.

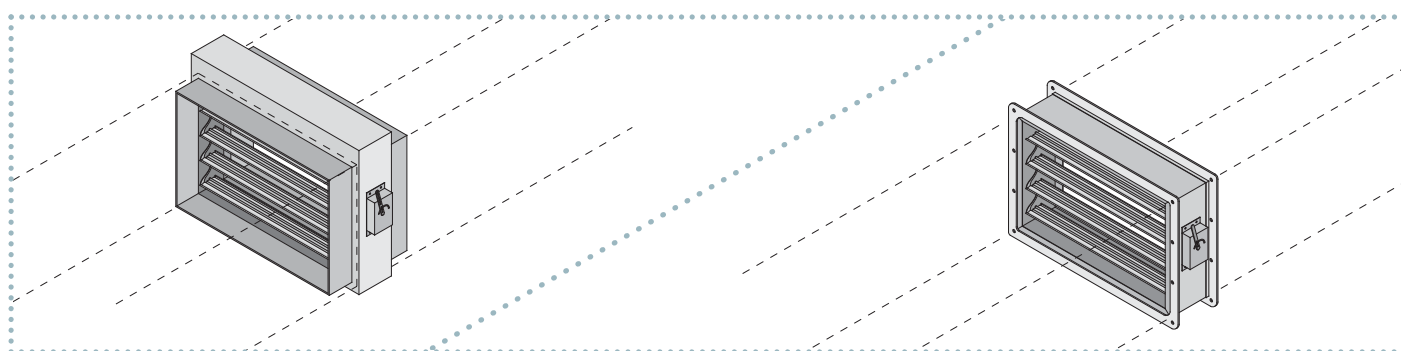

All types of damper systems can be used where appropriate, with provision for access to these items for maintenance purposes. Details on the right show installation of dampers within DURADUCT systems.

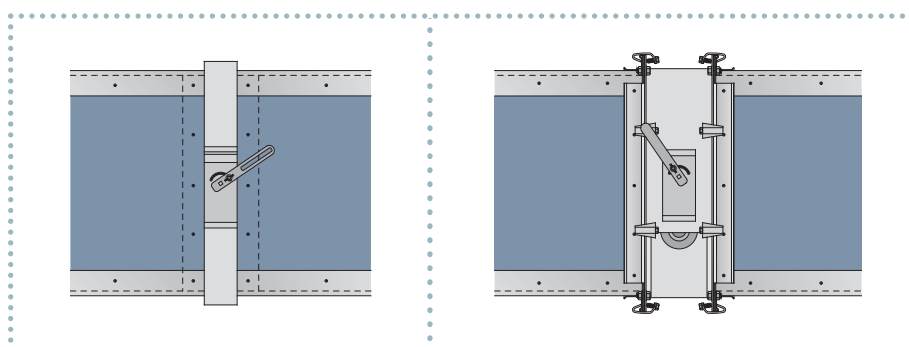

Details below show how items such as VCU, Silencers etc can be housed within the DURASTEEL® ductwork systems. For specific construction details, please consult your local Intumex Asia Pacific office.

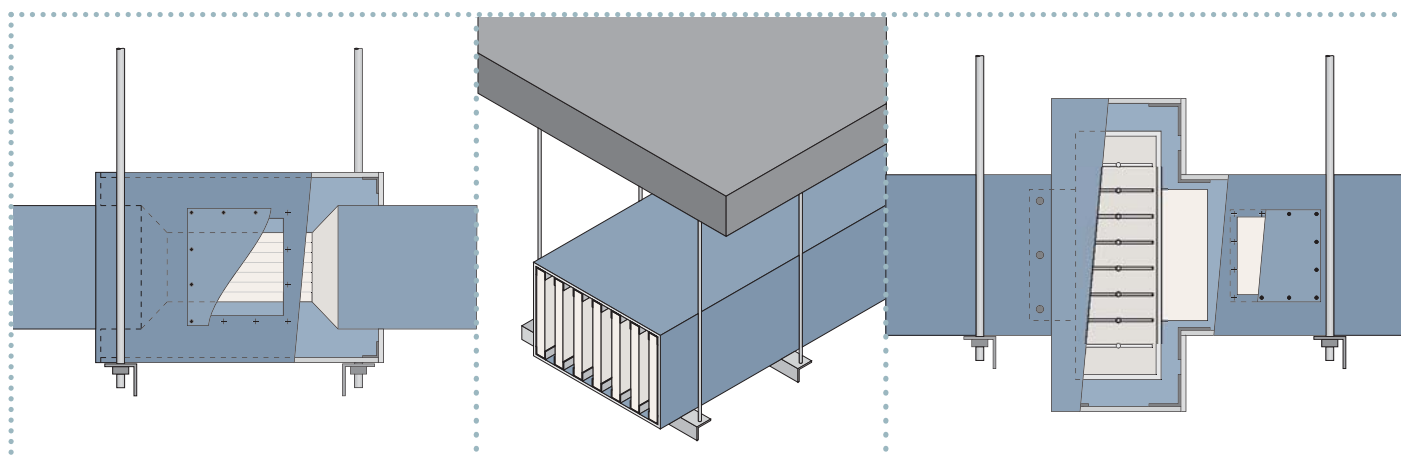



Introducing DURASHAFT Vertical Ducting

Features

- Maximises lettable floor area.
 - Requires up to 40% less floor space than conventional multi-service riser systems.
 - Eliminates the need for internal thin-gauge steel ducting.
 - Fire resistant inside and outside the duct.
 - Splitters replace independent ducts.
 - Very early installation.
 - No protruding fixings on internal face.
 - Complete fire and smoke seal at every floor.
 - Pressure resistance: +/- 2 kPa Classes A, B or C to DW 144*.
 - Prefabrication of complete sections where appropriate.
 - Direct fixing of services eliminates secondary supports.
 - Excellent acoustic insulation.
 - Dampers and fans can be incorporated.
 - Fast construction method.
- *DW144: Specification for sheet metal ducting published by the Heating & Ventilating Contractors Association.

Fire Rating Performance

- 4-hour integrity and stability with 1 or 2-hour insulation (either side).

Types of Application

DURASHAFT is a revolutionary pressurized shaft system developed for today's high-rise buildings. It eliminates the need for internal steel ducting, releasing more usable floor area and is robust enough to withstand the construction environment, enabling it to be installed early in the building programme.

DURASHAFT is a vertical duct construction, which can run through the entire height of a building uninterrupted.

An example of DURASHAFT construction is as below, see drawings on the opposite page.

9.5 mm thick DURASTEEL® sheet with outer plasterboard lining.

DURASHAFT is a fully tested construction, capable of withstanding high differential pressures (+/- 2kPa) and spanning up to 4000mm story heights (floor to floor).

The precise configuration for each project is designed as a bespoke system, considering all performance requirements such as applied pressures, leakage parameters and cross sectional area.

If required, the design can incorporate additional sub assemblies such as side inlets, access and inspection panels, fire dampers and fans.

DURASHAFT is assembled on site from component parts, consisting of the inner DURASTEEL® skin ① providing a tough impact resistant inner liner, an external exoskeleton framing ③ especially designed to meet project performance parameters, and an external gypsum liner ② providing enhanced acoustic and insulation performances. The whole is fixed at each floor slab level by means of steel brackets.

DURASHAFT Vertical Ducting Construction Details

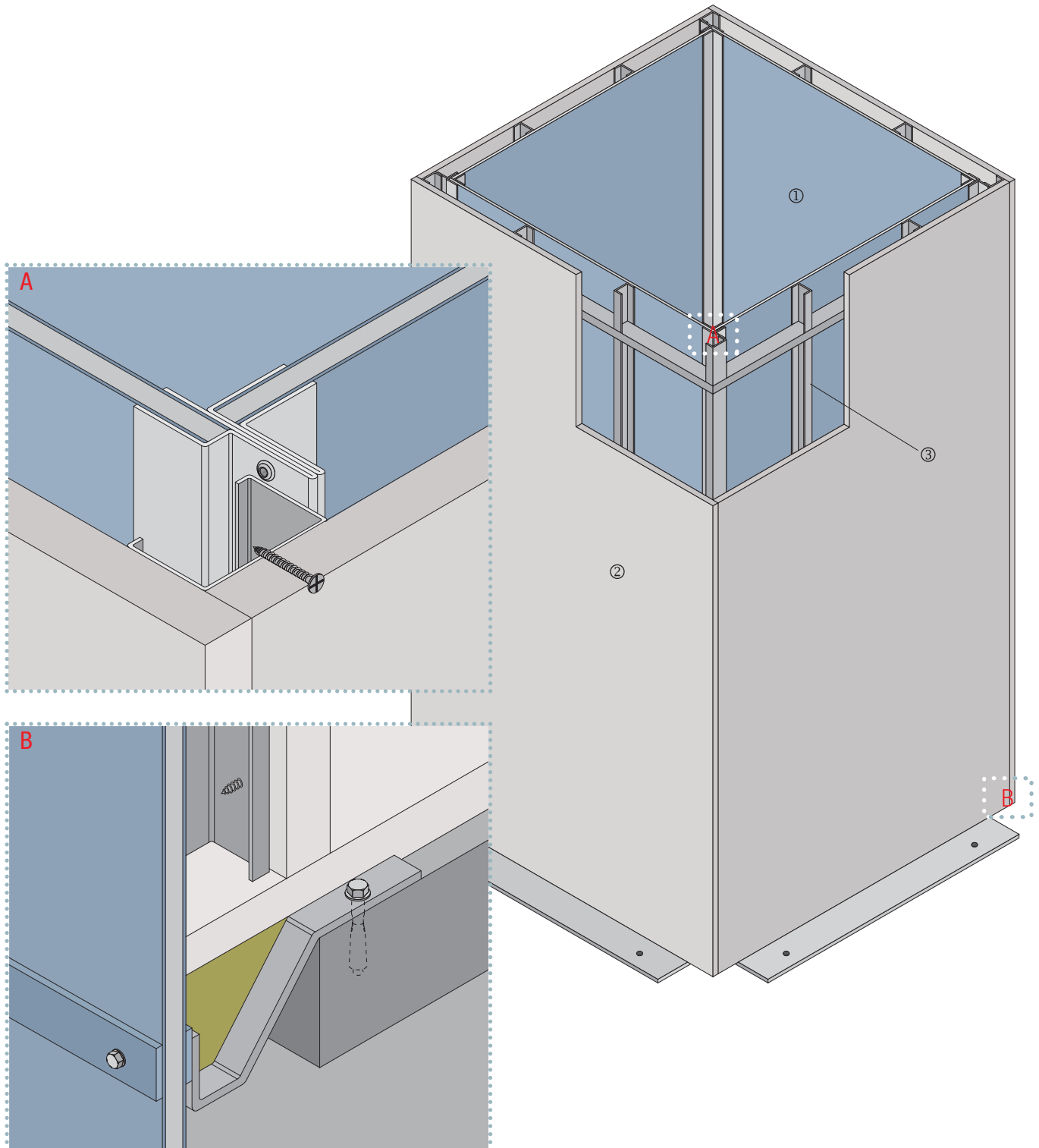



Project References

DURASTEEL® fibre cement and steel composite board is well known for its high impact performance and has been extensively used in many noteworthy projects over the countries in Asia Pacific and Europe, such as the following:

PROJECTS	APPLICATIONS	YEAR
K.C.R.C. EastRail extension, HONG KONG	Smoke extraction duct, access doors, plenum ceiling, services enclosure	2004
Wanchai Police Headquarters (phase 3), HONG KONG	LT duct for smoke extraction, plenum ceiling, services enclosure, town gas pipe enclosure, bulkhead for fire shutters, smoke barrier	2004
M.T.R.C. Stations Improvement, HONG KONG	Smoke extraction ducts, fire doors, kiosk fire separation, services enclosure	1997~2004
School Improvement Programme (phase 1, 2, 3 & 4), HONG KONG	Services enclosure, fire barrier, ventilation ducts	1995~2004
Sub-stations for H.K. Electric Company, HONG KONG	Services enclosure, ventilation duct	1992~2004
Government Housing Developments, HONG KONG	Ventilation ducts, services enclosure	1990~2004
Hong Kong University extension, HONG KONG	Loadbearing floor, services enclosure, ventilation ducts	1990~2004
Sub-stations for China Light & Power Ltd., HONG KONG	Cable trench cover, services enclosure	1990~2004
Brisbane bus tunnel	Ducting/shield	2003
H.K. Chinese Women's Club College, HONG KONG	Loadbearing ceiling	2003
K.C.R.C. WestRail stations and tunnels, HONG KONG	Smoke extraction duct, access doors, floor hatches, plenum ceiling, services enclosure, demountable fire barrier	2003
Kwai Chung Cargo Terminals, HONG KONG	Smoke vents, services enclosure, fire doors, fire barrier, bulkhead for fire shutters	1990~2003
Charter House, HONG KONG	Smoke extraction duct, services enclosure, access doors with architectural finishes	2002
M.R.T.C. North East Line, SINGAPORE	Ventilation and smoke extract duct, demountable fire barrier, access floor hatch	2002
M.T.R.C. Tseung Kwan O extension (stations and tunnels), HONG KONG	Smoke extraction duct, access doors and hatches, services enclosure, town gas pipe enclosure	2002
Olympic Station Commercial & Residential Development (phase 1, 2 & 3), HONG KONG	Smoke vents, access hatches, services enclosure, smoke barrier, bulkhead for fire shutters	2000~2002
New World First Depot, HONG KONG	Smoke extraction duct, services enclosure	2000
The University of Science & Technology, HONG KONG	Services enclosure, fire doors, ventilation duct	1992~2000
Harbour Plaza Resort City, HONG KONG	Smoke extraction ducts, smoke vents, services enclosure, plenum ceiling, bulkhead for fire shutters	1999
London Underground: Jubilee Line extension, U.K.	Fire rated and non-fire rated ventilation ductwork	1993~1999
Cheung Kong Center, HONG KONG	Smoke extraction duct, smoke vents, services enclosure, smoke barrier, lift shaft duct	1998
International Finance Centre One, HONG KONG	Smoke extraction, smoke barrier, services enclosure	1998

Project References

PROJECTS	APPLICATIONS	YEAR
Louis Vuitton at Canton Road, HONG KONG	Loadbearing floor	1998
Lantau Airport Railway (stations and tunnels) HONG KONG	Smoke extraction duct, fire doors, smoke barrier, services enclosure, plenum ceiling	1996~1998
Cathay Pacific Catering Services, HONG KONG	Smoke extraction duct, services enclosure, fire door	1997
Hong Kong International Airport, HONG KONG	Sliding fire door, smoke extraction duct, services enclosure	1997
HSBC Building, HONG KONG	Loadbearing floor, services enclosure	1997
North District Hospital, HONG KONG	Services enclosure, town gas pipe enclosure	1997
Royal Ascot Commercial & Residential Development, HONG KONG	Smoke vents, services enclosure, loadbearing floor	1997
Tuas Bay tunnel, SINGAPORE	Joint cover	1997
Western Harbour crossing, HONG KONG	Smoke extraction duct, movement joints	1997
Labrador sub-station, SINGAPORE	Floor opening	1996~1997
Australia Shopping Centre, AUSTRALIA	Ducting system	1996
Comcentre, SINGAPORE	2 hours plenum ceiling	1996
Hollywood Plaza, HONG KONG	Smoke vents, fire doors	1996
Hunghom Freight extension, HONG KONG	Smoke extraction duct, plenum ceiling	1996
Kwinana Power Station (coal), AUSTRALIA	Smoke barriers, fire doors	1996
Nestle Dairy Farm Factory, HONG KONG	Smoke extraction duct, services enclosure	1996
Sydney harbour tunnel, AUSTRALIA	Expansion joint protection, fire doors	1996
Telepark, SINGAPORE	2 hours plenum ceiling	1996
United Christian Hospital, HONG KONG	Services enclosure, ventilation ducts	1996
Woodlands sub-station, SINGAPORE	Trench cover	1996
Tampines Mall, SINGAPORE	2 hours plenum ceiling	1995~1996
Temasek Polytechnic, SINGAPORE	2 hours enclosure	1995~1996
Republic Plaza, SINGAPORE	2 hours trafficable ceiling	1994~1996
Senoko Power Station, SINGAPORE	Fire barrier	1994~1996
Suntec City (phases 3, 4 & 5), SINGAPORE	2 hours trafficable ceiling	1993~1996
Nethersole Hospital, HONG KONG	Plenum ceiling, services enclosure	1995
AIA Tower, SINGAPORE	2 hours enclosure	1994
AutoPlaza, HONG KONG	Loadbearing floor	1994
New Century Hotel & Plaza, HONG KONG	Smoke extraction duct, smoke vents, smoke barrier, services enclosure, plenum ceiling, fire doors	1994

Continued on next page

Project References

Continued from previous page

PROJECTS	APPLICATIONS	YEAR
Times Square, HONG KONG	Services enclosure, bulkhead for fire shutters	1994
Black Point Power Station, HONG KONG	Ventilation ducts, fire doors, services enclosure	1993
Boy Scout Headquarters, HONG KONG	Smoke vents, services enclosure	1993
Corporation Place, SINGAPORE	4 hours ceiling	1993
International Finance Centre Two, HONG KONG	Smoke barrier, insulated fire doors, ventilation ducts, services enclosure	1993
Lane Crawford Place, SINGAPORE	2 hours pipe enclosure	1993
Tate's Cairn Tunnel, HONG KONG	Cable enclosure, plenum cable	1993
British Rail: Waterloo International Rail Terminal, U.K.	Ductwork	1992
Channel Tunnel, U.K.	Cable enclosure	1992
City Bank Headquarters & Plaza, HONG KONG	Smoke vents, fire doors, services enclosure	1992
London Underground: Bow Road Station, U.K.	Fire doors	1992
Route 5 road tunnel, HONG KONG	Cable trunking enclosure	1992
M.R.T.C., SINGAPORE	Smoke extract duct, plenum ceiling, fire barrier, access floor hatch, fire door	1989~1992
M.T.R., HONG KONG	Cable enclosure, plenum ceiling, duct, fire wall, plant room enclosure	1988~1992
Bank of China, HONG KONG	Services enclosure, ventilation ducts	1991
Dragon Centre, HONG KONG	Smoke extraction duct, smoke vents, fire doors, services enclosure, plenum ceiling	1991
London Underground: New Angel Station, U.K.	Cable enclosures and separation, stairway protection	1991
Miramar Hotel, HONG KONG	Smoke vents, services enclosure	1991
Peninsula Hotel extension, HONG KONG	Smoke extraction duct, smoke vents, fire doors, services enclosure	1991
British Rail: St. Pauls Thames Link, U.K.	Smoke ventilation ductwork	1990
Garwick Airport, U.K.	Ventilation and smoke extract duct	1990
Pacific Place Two, HONG KONG	Smoke vents, smoke barrier, ventilation ducts, services enclosure, bulkhead for fire shutters, drencher bulkhead	1990
Shing Mun Tunnel, HONG KONG	Cable enclosure	1989
Stanstead Airport, U.K.	Smoke extract duct, fire barrier, fire door	1989
Sydney Harbour tunnel, AUSTRALIA	Protection to joints	1989
The 2nd Cross Harbour tunnel, HONG KONG	Fire door, cable protection, service enclosure	1989
HSBC Headquarters, HONG KONG	Smoke extraction duct, services enclosure	1985

Approval of Codes & Standards

DURASTEEL® systems have also been tested to many international standards below and many other national standards:

- **AS 1530: Various parts** AUSTRALIA
- **CAN 4-S114-M80** CANADA
- **China Fire Rules & Regulations 1984** P.R. CHINA
- **Arreté du 30 Juin 1983** FRANCE
- **Arreté du 21 Avril 1983** FRANCE
- **DIN 4102: Various parts** GERMANY
- **DIN 52104** GERMANY
- **PA III 4.596** GERMANY
- **BS 476: Various parts** U.K.
- **ASTM E 119** U.S.A.
- **ASTM E 136** U.S.A.

Approvals for DURASTEEL® systems have been given by the following organisations:

- **Hong Kong Fire Services Department** HONG KONG
- **EdF (Electricité de France)** FRANCE
- **Det Norske Veritas** NORWAY
- **Lloyds Register** U.K. (Worldwide)
- **Building Research Establishment** U.K.
- **Loss Prevention Council** U.K.
- **UL (Underwriters Laboratories)** U.S.A.
- **FM (Factory Mutual)** U.S.A.
- **ABS (American Bureau of Shipping)** U.S.A.

Working With DURASTEEL®

Quality Assurance

Intumex Asia Pacific has always been committed to the highest standards of quality. Our DURASTEEL® board manufacturing and production systems operate under a rigorous quality management system, independently certified as complying with BS EN ISO 9000. This provides specifiers, contractors and end users with an independent assurance of our continuous quality control of production.

On-site Quality Control

Intumex Asia Pacific will provide a full technical back up to the (sub) contractor both on and off site. This will include assistance in the form of providing written confirmation of construction details, together with drawings where required. Please note however that this refers only to specific detail drawings and does not relate to the provision of the shop drawings unless otherwise agreed.

Intumex Asia Pacific will visit site on a frequency to be agreed between ourselves, the (sub) contractor and the main contractor to ensure that installation is proceeding in accordance with our recommendations.

Composition & Manufacture

DURASTEEL® is a composite panel of fibre reinforced cement, mechanically bonded to punched steel sheets on both faces. DURASTEEL® is non combustible and is classified as a Class 0 material.

Continued on next page

Working With DURASTEEL®

*Continued from
previous page*

Health & Safety

No special precautions are necessary in handling or working boards. When using power saws or sanders in a confined space, dust extraction equipment is recommended to control dust levels.

DURASTEEL® will support its own weight and also can be used in load bearing situations; please consult Intumex Asia Pacific Technical Services Department for advice. Installers must ensure that they work from adequate and safe platforms where necessary.

Health and Safety data sheets are available.

Handling & Storage

Carry boards on edge, and do not drop on their corners or on to trestles. All products should be stored under cover on a flat base, clear of the ground. If stored in the open, the stack should be fully protected from the weather. If stored on racks or dunnage, boards should be fully supported across their width at not more than 1m centres.

Maintenance & Cleaning

Boards do not normally require any maintenance in use. DURASTEEL® boards will not crack or deteriorate with normal usage, as it is the most rugged board product available within the passive fire protection market. DURASTEEL® boards can be degreased with a mild solvent should painting or plastering be required (see [Decorating](#)).

General

Care should be taken to prevent injury from sharp edges and corners. Do not leave boards lying about on site, on scaffolding or in high traffic areas, where risk of damage or injury is increased, and prevent any misuse which could result in personal injury or damage to boards. In the event of injury, obtain proper treatment. The materials and the packaging used for distribution do not incorporate any substances considered to be hazardous to health.

Working

CUTTING & SAWING

Use a jig saw with a coarse blade. Diamond dusted blades are available in some countries and will assist in prolonging the life of the blades. In general, cutting with a jigsaw is only suitable for small cuts, e.g. scribing around services etc.

For long cuts, a jigsaw blade can be used, but has limitations on its effectiveness, short life span of jigsaw blades is an issue and straightness of cuts. For many long cuts, use a grinder or a guillotine if available. Note that when cutting boards with a grinder, the edges are extremely sharp and thus extra care should be taken to avoid cutting of hands etc. See below for details on dressing of edges.

Always wear suitable eye and hand protection. Ideally, masks should be worn to prevent inhalation of dust.

DRILLING

Use a hand drill or high speed power drill (not the percussion type); bits should have HSS tips and should be suitable for drilling steel and/or fibre cement. Always wear suitable eye and hand protection. Ideally, masks should be worn to prevent inhalation of dust.

EDGE TREATMENT

A file or grinder can be used to remove sharp or burred edges due to cutting of the sheets. Care should be taken not to remove large areas of the galvanised coating as this could possibly lead to corrosion of the steel. When cut, edges do not need to be coated in order to provide additional protection as galvanic reaction will prevent corrosion of edges. However, this does depend on the location of the system and its exposure to inclement conditions. Please consult Intumex Asia Pacific if in any doubt. Always wear suitable eye and hand protection. Ideally, masks should be worn to prevent inhalation of dust.

Decorating

PLASTERING

If a skim finish is desired, it will be necessary to apply a grid of expanded metal lathing to provide a key for plaster or sand and cement render. Please consult Intumex Asia Pacific for specific recommendations.

PAINTING & DECORATING

Any conventional paint can be used. Alkali resistant primers are not necessary. Water based paints (with a watered down first coat) or oil based paints can be applied to all products using proprietary primer/top coat systems as recommended by paint manufacturers. DURASTEEL® should be de-greased with a solvent based cleaning agent. All paints should be compatible with application to:

- 1) the galvanised steel facing, and
- 2) the core material has a high alkali content.

At all times the recommendations of the paint manufacturer should be followed.

Intumex Asia Pacific

HONG KONG

Room 1011, C.C. Wu Building
302-308 Hennessy Road
Wanchai

Tel: +852 2895 0265
Fax: +852 2576 0216

AUSTRALIA

Unit 1, 175 Briens Road
Northmead, NSW 2152
Tel: +61 (2) 9683 2872
Fax: +61 (2) 9630 0258

SINGAPORE

10 Science Park Road
#03-14 The Alpha
Singapore Science Park II
Singapore 117684
Tel: +65 6292 7888
Fax: +65 6294 2576

Email: info@intumex-ap.com

www.intumex-ap.com

Intumex Asia Pacific

Your local supplier