

# RIEMPITORE DI PLATEAUX VSD-115

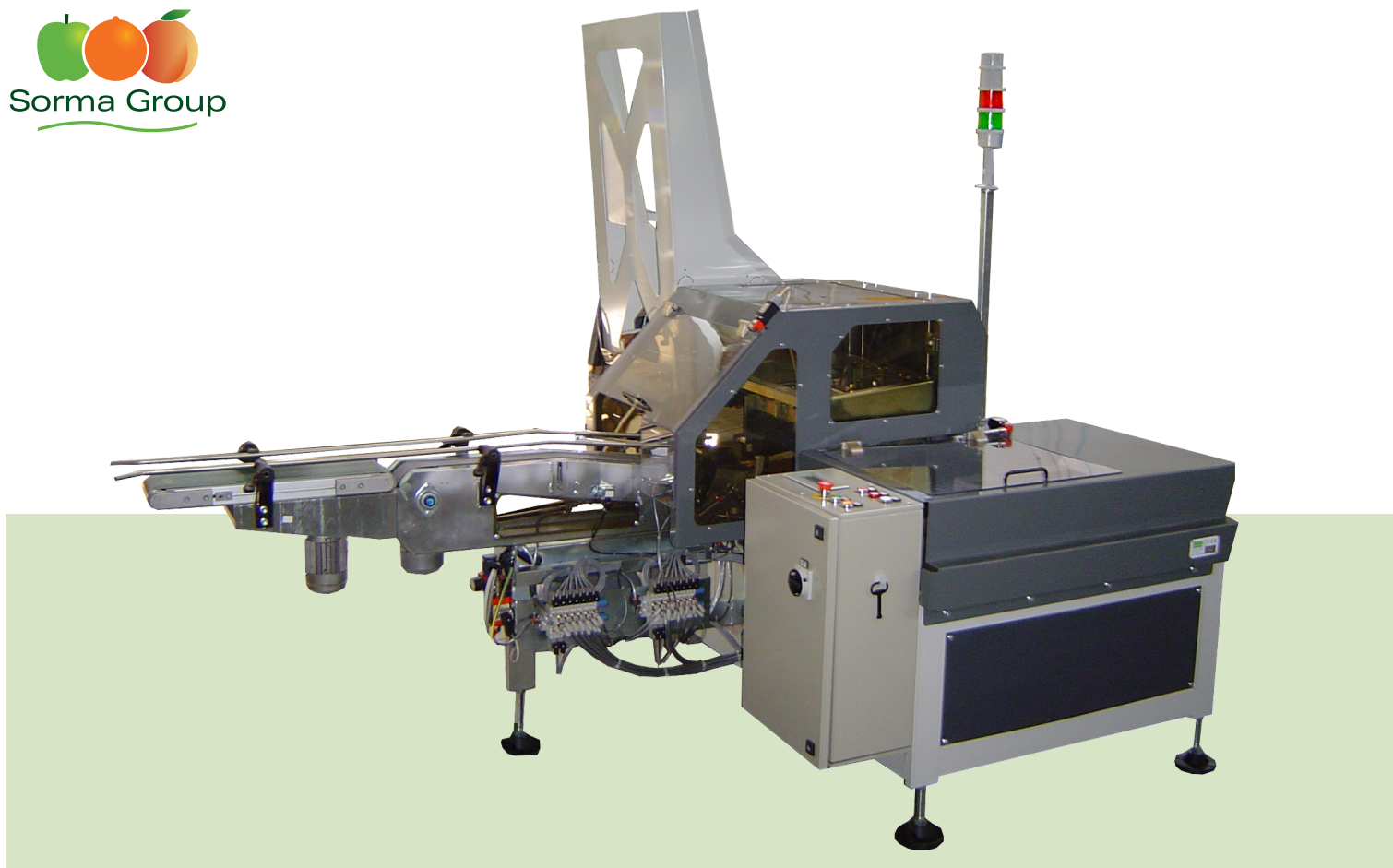

## Riempitore di plateaux mod. VSD-115

Adatto all'inserimento di cestini retinati da 1 kg (o 0,5 kg) in plateaux di cartone formato: 40x60 cm o in casse ifco o steco 40x60 cm. Può essere accoppiato a qualsiasi retinatrice che lavori cestini da 0,5/1 kg.



## BOX filler mod. VSD-115

Suitable for filling card boxes size 40x60 cm or ifco or steco boxes size 40x60 cm with 1 kg (or 0,5 kg) netted punnets. Can be combined with any netting machine able to work 0,5/1 kg punnets.



## Remplisseuse pour plateaux mod. VSD-115

Indiquée pour l'introduction de barquettes mises sous filet de 1 kg (ou 0,5 kg) dans des plateaux en carton format: 40x60 cm ou dans des caisses ifco ou steco 40x60 cm. Elle peut être associée à tout type de manchonneuse adaptée à des barquettes de 0,5/1 kg.



## Befüllmaschine für Umkartons mod. VSD-115

Zum Einsetzen von netzgeclippten 1 kg (oder 0,5 kg) - Schalen in Umkartons, Format: 40 x 60 cm, oder in Ifco - und Steco-Kisten, 40 x 60 cm. Kann mit jeder Netz - Clipmaschine für Schalenmaschine die 0,5/1 kg-Schalen verarbeitet kombiniert werden.



## Llenadora de bandejas mod. VSD-115

Apta para colocar cestas de 1 kg (o 0,5 kg) con malla en bandejas de cartón de 40x60 cm o en cajas ifco o Steco de 40x60 cm. Puede conectarse con cualquier enmalladora que elabore cestas de 0,5/1 kg.



## НАПОЛНИТЕЛЬ КОРОБОК модель VSD-115

Подходит для заполнения картонных коробок, размером 40x60 см или коробок ifco или steco, размером 40x60, корзинками в сетке, весом 1 кг(или 0.5 кг). Можно совмещать с любой упаковывающей в сетку машиной, работающей с корзинками 0.5/1 кг.

## DATI TECNICI/TECHNICAL DATA

PRODUZIONE  
OUTPUT  
PRODUCTION  
LEISTUNG  
PRODUCCIÓN  
Производство

circa 60 cestini al minuto  
approx. 60 punnets / minute

POTENZA ELETTRICA INSTALLATA  
INSTALLED POWER  
PUISSANCE ELECTRIQUE INSTALLÉE  
ANSCHLUSSWERT ELEKTR  
POTENCIA ELÉCTRICA INSTALADA  
Установленная мощность

1 kW - 50 Hz - 400 V

CONSUMO ARIA  
AIR CONSUMPTION  
CONSOMMATION D'AIR  
LUFTVERBRAUCH  
CONSUMO DE AIRE  
Потребление воздуха

300 NI/min - 6 bar

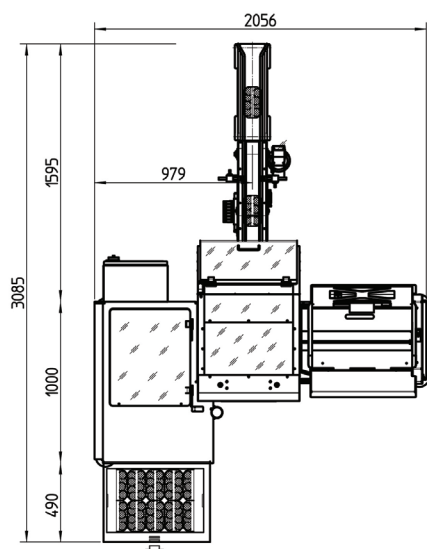
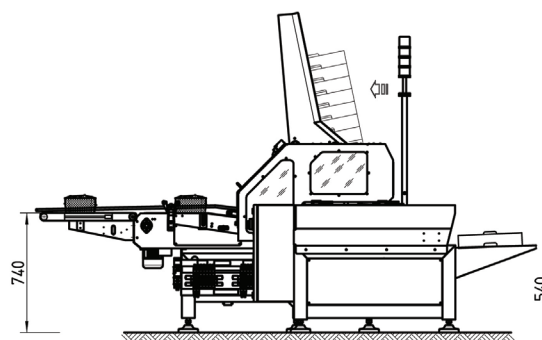
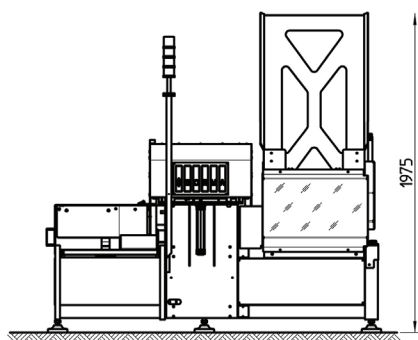

## RIEMPITORE DI PLATEAUX VSD-115

AGENTE DI ZONA / LOCAL DEALER



**SORMA S.p.A.**

via Delle Mele, 65 - 47522 Cesena (FC) - ITALY

Tel. (+39) 0547 418611 - Fax. (+39) 0547 418612

sorma@sormaitalia.com - www.sormagroup.com