

Impact 2525 Recessed

LINEAR LED

Product code

ME08RE

mondolux.com.au

MONDOLUX™

Installation Manual



Notes

- This fitting requires 220-240V AC/50Hz power input to the driver. Installation should be done by qualified electrician.
- Electrical Wiring and installation should always comply as per the local standards.
- Do not open or interchange any parts of this fitting or the warranty is void.
- The fitting may be hot to touch after continuous use.
- Do not install the fitting near heat source.
- Do not install any inductive loads such as exhaust fans or pond pumps etc. within the same lighting circuit of this fitting. Issues caused by such wirings are not covered under our warranty policy.
- If you have any questions about the installation of this product, please contact Mondolux at 1300 601 931.

Care & Refinishing

Mondolux strongly recommends following cleaning procedures to maintain proper finish of the product.

- Do not use bleach or concentrated solvents under any circumstances.
- For Black finish: Wipe gently with a soft damp cloth or chamois. Do not use any abrasive compounds.

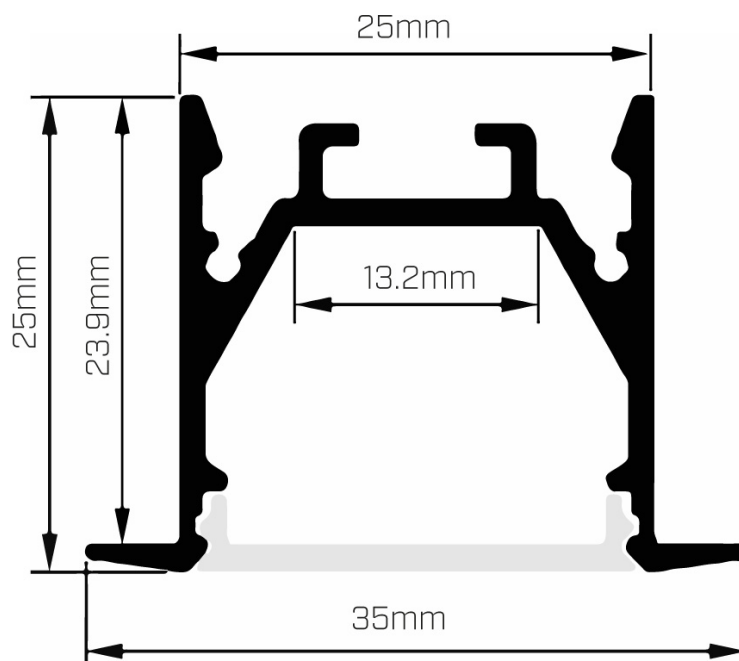

Impact 2525 Recessed

LINEAR LED

Product code ME08RE

mondolux.com.au

MONDOLUX™

Installation Steps

1. Ensure the mains power is turned off.
2. Impact 2525 Recessed Extrusion comes with required number of spring clips based on the length requested. At one point, only 1 spring clip is required to hold the extrusion in position. See Picture 1.
3. Adjust the spacing of the spring clips mounted on the base of extrusion by sliding them back and forth, to get the best grip. Slide the remote driver and then the extrusion into ceiling. See Picture 2.
4. Turn on the mains. Installation is complete. See picture 3.

Picture 1

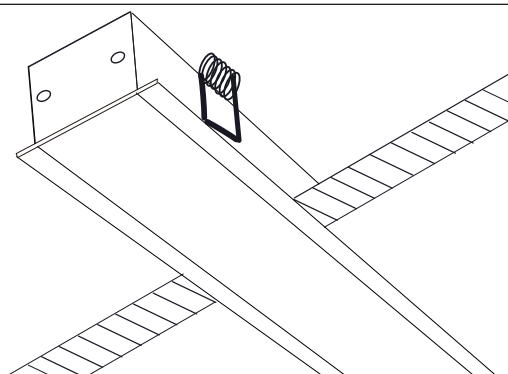

Picture 2

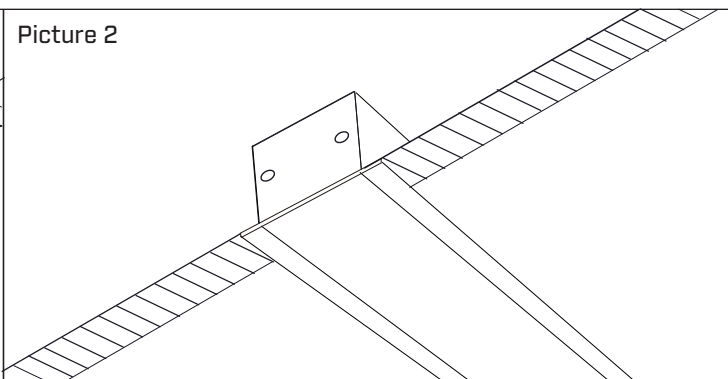

Picture 3

