

PRODUCT SPECIFICATION

Version:

A0

DATE:

2019-09-21

DOC No:

For Any detail and question, Please Tel Engineer:

FAX:

CUSTOMER NO:

Specification Approval Sheet 规格确认书

MODEL/型号: DLN18650*48V

(48V 20Ah)

Prepared By/Date 编制/日期	Checked By/Date 审核/日期	Checked By/Date 审核/日期	Approved By/Date 批准/日期
黄仁标/2019-11-21		钟务杰/2019-11-21	

Customer Approval 客户确认	Signature/ 签字	Date/ 日期
	Company Name/公司名称	
	Company Stamp/公司印章	

PRODUCT SPECIFICATION

Version:

A0

DATE:

2019-09-21

DOC No:

For Any detail and question, Please Tel Engineer:

FAX:

Revision 版本	Description/ 记述	Prepared by 编制	Approved by 批准	Date/ 日期

Records/修正记录

PRODUCT SPECIFICATION

Version:

A0

DATE:

2019-09-21

DOC No:

For Any detail and question, Please Tel Engineer:

FAX:

Content/目录

1. Scope/适用范围	Page 4
2. Model/型号	Page 4
3. Cell Specification/电芯规格说明	Page 4/5
4. Battery/Cell performance test Criteria/电池性能标准	Page 6
4.1 Appearance inspection by visual/外观目测	Page 6
4.2 Environmental test condition/外界环境条件	Page 6
4.3 Electrical characteristics/电气特性	Page 6
4.4 Mechanical characteristics/机械特性	Page 7
4.5 Safety performance/安全性能	Page 8
5. Cell initial Dimensions/电芯初始尺寸	Page 9
6. Battery specification/产品规格	Page 10
7. PCM/保护板	Page 10
7.1 PCM specification /保护板参数	Page 10
7.2 PCM schematic circuit diagram/保护板电子原理图	Page 13
8. Battery Pack Dimensions/电池组尺寸	Page 14
9. Shell Details外壳详情图	Page 15
10. Handling of Cells /电池操作注意事项	Page 16
Prohibition short circuit/禁止电池短路	Page 16
Mechanical shock/机械撞击	Page 16
11. Notice for Designing Battery Pack/电池外壳设计注意事项	Page 16
11.1 Pack toughness/外壳坚韧度	Page 16
11.2 Cell fixing/电池的固定	Page 16
11.3 Inside design/外壳内部设计	Page 16
11.4 Tab connection /极片连接	Page 16
11.5 For mishaps/针对意外事件	Page 16
12. Notice for Assembling Battery Pack 电池装配注意事项	Page 17
13. Others/其它	Page 17
13.1 Cell connection/电池连接	Page 17
13.2 Prevention of short circuit within a battery pack/电池内部的短路预防	Page 17
13.3 Prohibition of disassembly/禁止拆卸	Page 17
13.4 Prohibition of dumping of cells into fire/不要把电池倾倒入火中	Page 17
13.5 Prohibition of cells immersion into liquid such as water/禁止浸泡电池	Page 17
13.6 Battery cells replacement/更换电池	Page 17
13.7 Prohibition of use of damaged cells/禁止使用损坏的电芯	Page 17
14. Period of Warranty/保质期	Page 18
15. Storage of the Batteries/电池的存放	Page 18
16. Other The Chemical Reaction/其它化学反应	Page 18
17. Note/注释	Page 18

PRODUCT SPECIFICATION

Version:

A0

DATE:

2019-09-21

DOC No:

For Any detail and question, Please Tel Engineer:

FAX:

1 Scope/适用范围

This specification is applies to describe the related Battery product in this Specification and the Battery/cell supplied by Hai Lei Battery Co., Ltd only.

本说明书只适用于描述本规格书中相关的产品以及海雷电池有限公司提供的电池。

2 Model/型号: ICR18650

3 Cell Specification/电芯产品规格

No.	Items/项目	Specifications/规格		Remark 备注
1	Nominal Capacity 标称容量	3200mAh		0.5C Standard discharge 0.5C 标准放电
2	Minimum Capacity 最小容量	3000mAh		
3	Nominal Voltage 标称电压	3.6V		Mean Operation Voltage 即工作电压
4	Delivery voltage 交货电压	>3.8V		Within 10 days from Factory 在出厂 10 天内
5	Charge Voltage 充电电压	4.25V±0.05V		By standard charge method 标准充电方式
6	Standard charging method 标准充电方式	0.3C constant current 4.25V constant voltage charge to 4.25V, continue charging till current decline to ≤0.01C		0.3C 恒流 4.25V 恒压充至电流≤0.01C, 时间约4h(供参考)
7	Charge current 充电电流	0.3C	900mA	Standard charge, charge time about 4h(Ref) 标准充电, 时间约 4h(供参考)
		0.5C	1500mA	Rapid Charge, charge time about: 2h(Ref) 快速充电, 时间约 2h(供参考)
8	Standard discharging method 标准放电方式	0.3C constant current discharge to 2.5V,		0.3C 恒流放电至 2.75V
9	Cell Internal Impedance 单电芯内阻	≤30mΩ		Internal resistance measured at AC 1KHz after 50% charge 半电态下用交流法测量内阻

PRODUCT SPECIFICATION

Version:

A0

DATE:

2019-09-21

DOC No:

For Any detail and question, Please Tel Engineer:

FAX:

3 Cell Specification/电芯产品规格

No.	Items/项目	Specifications/规格		Remark 备注
10	Maximum charge current 最大充电持续电流	0.5C	1500mA	For continuous charging mod 连续充电模式
11	Maximum discharge current 最大放电持续电流	2.5C	7500mA	For continuous discharge mod 连续放电模式
12	Operation Temperature and relative humidity Range 工作温度和湿度范围	Charge/充电	0~55℃ 60±25%R.H.	Charge at a very low temperature such as blew 0℃,will be get a lower capacity and reduce cycle life of the battery 低温充电效率会下降，会影响电池使用寿命
		Discharge/放电	-20~60℃ 60±25%R.H.	
13	Storage temperature for a long time 长时间储存温度	-20~45℃ 60±25%R.H.		Do not storage exceed half year. Must charge once when storage for half year. must charge the battery which with protect circuit when storage for three months. 不可超过半年,达到半年须充电一次 带保护板电池 3 个月充电一次
14	Temperature Dependence of discharge capacity (放电温度特性)	<p>Cells shall be charged per 3.3.1 and discharged @0.2 C₅A to 3.0 volts. Except to be discharged at temperatures per Table 3. Cells shall be stored for 3 hours at the test temperature prior to discharging and then shall be discharged at the test temperature. The capacity of a cell at each temperature shall be compared to the capacity achieved at 23 °C and the percentage shall be calculated. .</p> <p>电池按 3.3.1 规定充电。按表 3 的温度中放电， 电池必须先在该试验温度 中放置 3 个小时。</p>		Each cell shall meet or exceed the requirements of Table 3 温度中的放电容量应不小于表 3 的要求

PRODUCT SPECIFICATION

Version:

A0

DATE:

2019-09-21

DOC No:

For Any detail and question, Please Tel Engineer:

FAX:

4 Battery/Cell performance test Criteria/电池性能标准

4.1 Appearance inspection by visual/外观目测

There shall be no such defect as rust, leakage, which may adversely affect commercial value of battery.

电池外观应没有锈渍、污渍、漏液等影响商业价值的缺陷存在。

4.2 Environmental test condition/外界环境条件

Unless otherwise specified, all test stated in this product specification are conduct at below test condition

所有测试应按以下环境条件进行，除非特殊指定外。

Temperature: 23°C~27°C

Relative Humidity:60%±20% R.H.

4.3 Cell Electrical characteristics/电气特性

No	Items/项目	Test Method and Condition/测试方法及条件	Criteria/标准	
1	Rated Capacity at 0.2C(Min.) 0.2C 最小额定容量	After standard charge, the capacity shall be measured on 0.3C discharge till the voltage discharge to 2.75V, 标准充电后，放电至 2.75V,截止，测量 0.2C 放电容量	≥2800mAh	≥100%
	Rated Capacity at 0.5C(Min.) 0.5C 最小额定容量	After standard charge, the capacity shall be measured on 0.5C discharge till the voltage discharge to 2.75V, 标准充电后，放电至 2.75V 截止，测量 0.5C 放电容量	≥98%	
	Rated Capacity at 3C(Min.) 1C 最小额定容量	After standard charge, the capacity shall be measured on 1C discharge till the voltage discharge to 2.75V, 标准充电后，放电至 2.75V 截止，测量 1C 放电容量	≥95%	
2	Cycle Life 循环寿命	Charging and discharging battery as blew conditions 0.2C standard charge to 4.25V end-off 0.2C standard discharge to 2.75V cut-off Continuous charge and discharge for 500cycles ,the capacity will be measure after the 500 th cycle 充放电按以下条件： 0.2C 标准充电至 4.25V，0.2C 标准放电至 2.75V，连续充放电循环 500 周，在第 500 周结束后测量容量	≥65% of initial capacity	
3	Capacity retention 容量保持	The battery to be charge in accordance with standard charge condition at 23~27 °C ,then storage the battery at an ambient temperature 23~27°C for 28 days. Measure the capacity after 30 days with 0.5C at 23~27 °C as retention capacity 将电池在 20~25°C标准充电后储存在 23~27°C的环境中 28 天 28 天后，测试电池在 23~27°C环境下 0.5C 放电容量作为保持容量	Retention capacity 容量保持 ≥95%	

PRODUCT SPECIFICATION

Version:

A0

DATE:

2019-09-21

DOC No:

For Any detail and question, Please Tel Engineer:

FAX:

4.4 Mechanical characteristics/机械特性

No	Items/项目	Test Method and Condition/测试方法及条件	Criteria/标准
1	Free fall test 自由跌落测试	The battery to be fully charged in accordance with standard charge condition, then drop the battery three times from a height of 1,0 m onto a concrete floor. The batteries are dropped so as to obtain impacts in random orientations. 电池按照标准充电条件充满电, 然后从1m高度跌落电池到一个水泥地面, 随机跌落三次。	No Fire, No explosion, 不起火, 不爆炸
2	Vibration test 振动测试	After standard charging, fixed the cell to vibration table and subjected to vibration cycling that the frequency is to be varied at the rate of 1Hz per minute between 10Hz and 55Hz, the excursion of the vibration is 1.6mm. The cell shall be vibrated for 30 minutes per axis of XYZ axes. 将标准充电后的电芯固定在振动台上, 沿 X、Y、Z 三个方向各振动 30 分钟, 振幅 1.6mm, 振动频率为 10Hz~55Hz, 每分钟变化 1Hz。	No explosion, No leakage, No fire 无泄漏, 不起火, 不爆炸
3	Crush test 挤压测试	Fully charged the battery in accordance with standard charge condition, the battery is to be crushed between two flat plates. Continuous to applied force on battery of 13kN(17.2Mpa), stopped until a pressure reading of 17.2Mpa is reached on the hydraulic ram 电池按标准充电条件充满电, 放置在两块平面金属板间, 持续施加 13KN (17.2Mpa) 的压力, 直到液压油缸施加的压力达到 13KN (17.2Mpa) 时停止。	No fire, No explosion, 无起火无爆炸
4	Shock test 撞击测试	The fully charged battery is secured to the testing machine by means of a rigid mount which will support all mounting surfaces of the cell or battery. The battery is subjected to a total of three shocks of equal magnitude. The shocks are applied in each of three mutually perpendicular directions. At least one of them shall be perpendicular to a flat face. For each shock the cell or battery is accelerated in such a manner that during the initial 3 milliseconds the minimum average acceleration is 75 gn. The peak acceleration shall be between 125 gn and 175 gn. Cells or batteries are tested in an ambient temperature of 20~25°C	No explosion, No leakage, No fire 无泄漏, 不起火, 不爆炸

PRODUCT SPECIFICATION

Version:

A0

DATE:

2019-09-21

DOC No:

For Any detail and question, Please Tel Engineer:

FAX:

4.4 Safety performance/安全性能

No	Items/项目	Test Method and Condition/测试方法及条件	Criteria/标准
1	Thermal exposure test 高温热冲击测试	Each fully charged cell, stabilized at room temperature, is placed in a circulating air-convection oven. The oven temperature is raised at a rate of 5 °C/min ± 2 °C/min to a temperature of 130 °C ± 2 °C. The cell remains at this temperature for 10 min before the test is discontinued. 充满电的电池温度稳定到常温后, 放置入循环空气烘箱里, 从常温以5 °C/分± 2 °C/分的速率升至130°C后, 在130°C放置10分钟	No explosion, No fire 无起火,无爆炸
2	Short test 短路测试(20°C)	The fully charged battery is to be short-circuited by connecting the positive and negative terminals of the battery with resistance load not exceed 100m Ω .Tests are to be conducted at room temperature 20~25°C. 在室温 20~25°C把充满电的电池的正负极用不超过 100m Ω 的负载连接起来, 连接起来使电池外部短路	No explosion, No fire The Temperature of the Battery surface not exceeded than 150°C 无起火,无爆炸 电池表面温度不超过 150°C
3	Short test 短路测试(60°C)	The fully charged battery is to be short-circuited by connecting the positive and negative terminals of the battery with resistance load not exceed 100m Ω .Tests are to be conducted at room temperature about 60-65°C 在室温约为 60-65°C把充满电的电池的正负极用不超过 100m Ω 的负载连接起来, 连接起来使电池外部短路	No explosion, No fire The Temperature of the Battery surface not exceeded than 150°C 无起火,无爆炸 电池表面温度不超过 150°C
4	Forced discharge test 过放电测试	A discharged cell is subjected to a reverse charge at 1C for 90 min. 将电芯放完电, 再用 1C 反接充电 30 分钟	No explosion, No fire 无起火,无爆炸
5	Over charge test 过充电测试	After standard charge, continue to charge with a constant voltage 10V per a cell, holding 8h. 电芯标准充满电后, 以 5V 的恒定电压继续充电, 保持 8 小时	No explosion, No fire, 无爆炸, 无起火

PRODUCT SPECIFICATION

Version:

A0

DATE:

2019-09-21

DOC No:

For Any detail and question, Please Tel Engineer:

FAX:

5 Cell initial Dimensions/电芯初始尺寸

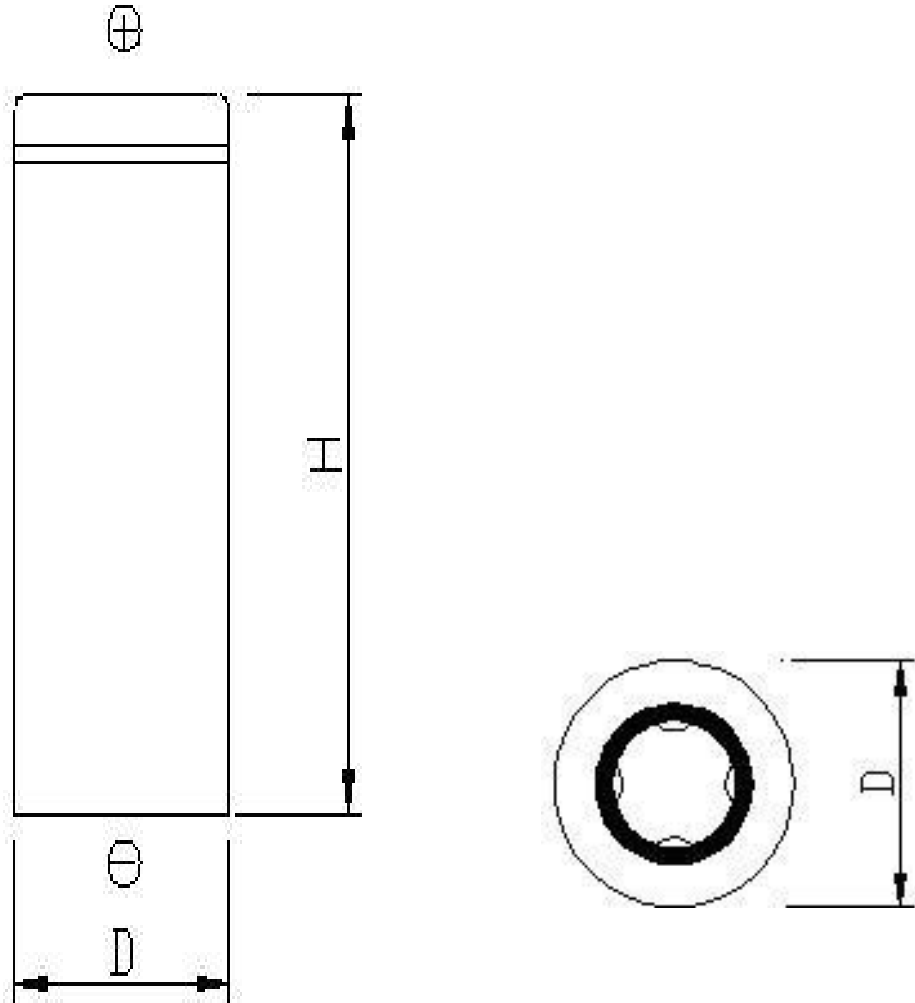

NO	Items	Units: mm
1	diameter/直径(D)	Max 18.2±0.10
2	Height/高度(H)	Max 65.3±0.30

6 Battery specifications/产品规格

No.	Items/项目	Specifications/规格	Remark 备注
1	Capacity for assembled cell discharging by 0.3C 电芯组装后 0.3C 标准放电的容量	≥19.5Ah	Standard discharging method 标准放电方式
2	Battery Voltage 电池电压	>49V	Delivery Voltage, Within 10 days from Factory 交货电压, 在出厂 10 天内
3	Standard charge condition 标准充电条件	Charge with 0.3C constant current and 54.6V constant voltage, charge to 54.6V, continue charging till current decline to ≤0.01C 充电电流用 0.3C 恒流, 54.6V 恒压充至电流 ≤ 0.01C	Charge volage: 54.6V ± 0.05V Charge current: 0.3C 充电电压: 54.6V ± 0.05V 充电电流: 0.3C
4	Standard discharging method 标准放电方式	0.3C constant current discharge to 39V,	0.3C 恒流放电至 39V
5	Internal Impedance 内阻	Assemblage Impedance 装配后内阻 ≤ 350 mΩ	Measure the Red and black wire of the connector after assembling. 装配后测试电池插头红黑线

7 PCM/保护板

7.1 PCM specification /保护板参数

项目 Projects	详细内容 Details	最小值 Minimum value	标准 Standards	最大值 Maximum value
4.0 充电参数 Charging parameter	1. 过充保护电压 Overcharge protection voltage	4.25V	4.30V	4.35V
	2. 过充保护延时 Overcharge protection delay	500mS	1000mS	1500mS
	3. 过充恢复电压 Overcharge recovery voltage	4.05V	4.10V	4.15V
	4. 额定充电电流 Rated charging current		20A	22A
4.1 放电参数 Discharge parameter	1. 单体过放保护电压 Overshoot protection voltage	2.30V	2.40V	2.50V
	2. 单体过放保护延时 Overshoot protection delay	500mS	1000mS	1500mS
	3. 单体过放解除电压 Overdischarge discharge voltage	2.80V	2.9V	3.10V
	4. 额定放电电流 Rated discharge current		20A	22A
	5. 放电保护电流 Discharge Protection Current	53A	60A	67A
	6. 放电过流延时 Overcurrent delay	50mS	100mS	150mS
	7. 短路保护 Short circuit protection		有	

	8. 短路保护恢复 Short circuit protection restored	断开负载		
4.2均衡参数 Equilibrium parameter	1. 均衡电压 Equalizing voltage	/	/	/
	2. 均衡电流 Equilibrium current	/	/	/
4.3内阻 Internal Resistance	1. B-, P-导通内阻 Conduction resistance	≤50mΩ		
4.4自耗电流 Consumable current	1. 保护自耗电 Protection of consumable power	≤70μA		
4.5(L*W*H)尺寸 Dimensions	1. 尺寸 Dimensions	64*50*12mm		

7.2 PCM schematic circuit diagram/保护板电子原理图

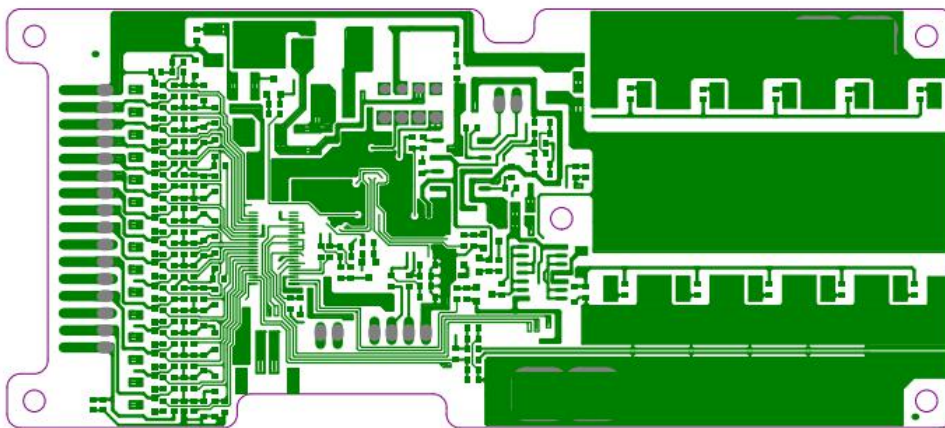

顶层走线图

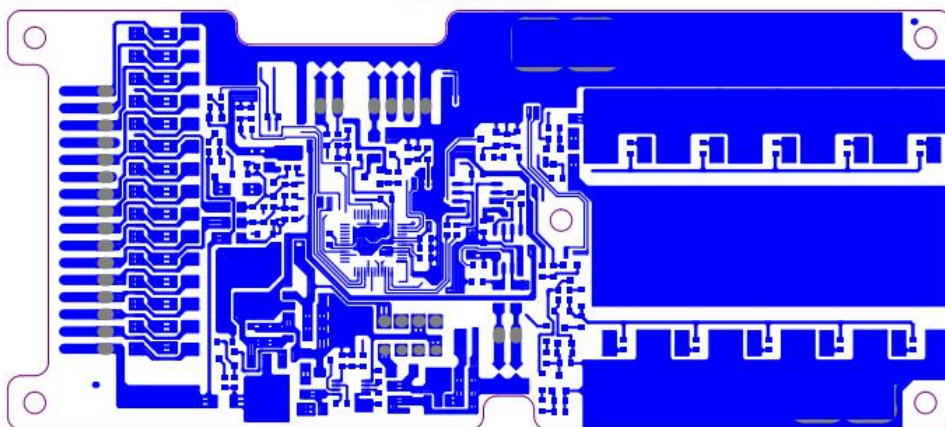

底层走线图

Battery Pack Dimensions/电池组尺寸

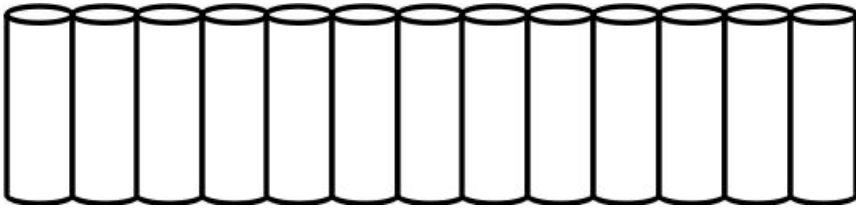

侧面展示图

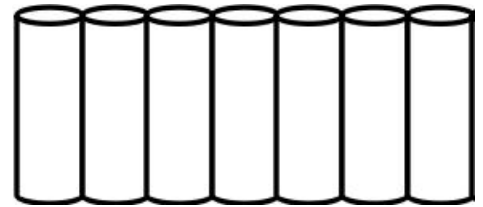

正面展示图

电池组尺寸：225*150*70

端口名称	端口功能	线型	线长
T母端	总输出 Total output	3135#16AWG	260MM
DC 端	总输入 Total input	3135#12AWG	260MM



8 Handling of Cells / 电池操作注意事项

8.1 Prohibition short circuit/禁止电池短路

Never make short circuit cell. It generates very high current which causes heating of the cells and may cause electrolyte leakage, gassing or explosion these are very dangerous.

The LIR tabs may be easily short-circuited by putting them on conductive surface.

Such outer short circuit may lead to heat generation and damage of the cell.

An appropriate circuitry with PCM shall be employed to protect accidental short circuit of the battery pack.

避免电池短路。短路会产生很高的电流而使电池发热以及电解液泄漏，产生有毒气体或爆炸是非常危险的。极片连接在导电物体表面很容易短路，外部短路会导致发热及损害电池。选用一个适当的保护电路可以在意外短路时保护电池。

9.2.Mechanical shock/机械撞击

Falling, hitting, bending, etc. may cause degradation of LIR characteristics.

跌落、碰撞、弯曲等等都可能会降低圆柱电池的性能。

9 Notice for Designing Battery Pack/电池外壳设计注意事项

9.1 Pack toughness/外壳坚韧度

Battery pack should have sufficient strength and the LIR cell inside should be protected from mechanical shocks.

电池外壳应该有足够的机械强度使圆柱电池免受机械撞击。

9.2 Cell fixing/电池的固定

The LIR cell should be fixed to the battery pack by its large surface area.

No cell movement in the battery pack should be allowed.

电池最大面积的一面应该固定在外壳上，安装后电池不能有松动。

9.3 Inside design/外壳内部设计

No sharp edge components should be insides the pack containing the LIR cell.

外壳内安装电池的部位不应有锋锐边。

9.4 Tab connection /极片连接

Ultrasonic welding or spot welding is recommended for LIR tab connection method.

Battery pack should be designed that shear force are not applied to the LIR tabs.

If apply manual solder method to connect tab with PCM, below notice is very important to ensure battery performance:

- 1) The solder iron should be temperature controlled and ESD safe;
- 2) Soldering temperature should not exceed 350°C;
- 3) Soldering time should not be longer than 3s;
- 4) Soldering times should not exceed 5 times, Keep battery tab cold down before next time soldering;
- 5) Directly heat cell body is strictly prohibited, Battery may be damaged by heat above approx. 100°C

建议使用超声波或点焊焊接方法；外壳设计应使极片不受外力。

如果使用人工焊接保护板，下面的注意事项对于确保电池性能非常重要：

- 1) 焊接烙铁的温度必须可控且可防静电；
- 2) 焊接时烙铁的温度不能超过 350°C；
- 3) 焊锡时间不能超过 3 秒钟；
- 4) 焊锡次数不能超过 5 次，待极片冷却后才能进行下一次焊锡；
- 5) 严禁直接加热电芯，高于 100°C 度会损害电芯。

9.5 For mishaps/针对意外事件

Battery pack should be designed not to generate heat even when leakage occurs due to mishaps.

- 1) Isolate PCM (Protection Circuit Module) from leaked electrolyte as perfectly as possible.
- 2) Avoid narrow spacing between bare circuit patterns with different voltage.

(Including around connector)

LIR battery should not have liquid from electrolyte, but in case If leaked electrolyte touch bare circuit patterns, higher potential terminal material may dissolve and precipitate at the lower potential terminal, and may cause short circuit. The design of the PCM must have this covered.

发生意外时外壳设计应考虑即使在电池出现漏液时也不会发热。

- 1) 尽量把保护电路与渗漏的电解液隔离开。
- 2) 在不同的电压情况下避免出现小间距的裸露电路——包括插头周围。
- 3) 圆柱电池不应该有来自电解液的液体, 但是一旦发生电解液渗漏触及裸露电路, 高电势端子材料可能会溶解然后沉淀到低电势端子, 可能会造成短路。保护板的设计必须含有覆盖保护层。

10 Notice for Assembling Battery Pack 电池装配注意事项

Shocks, high temperature, or contacts of sharp edge components should not be allowed in battery pack assembling process.

在电池装配过程中不允许撞击、高温或接触尖锐部分。

11 Others/其它

11.1 Cell connection/电池连接

- 1) Direct soldering of wire leads or devices to the cell is strictly prohibited.
- 2) Lead tabs with pre-soldered wiring shall be spot welded to the cells.

Direct soldering may cause damage of components, such as separator and insulator, by heat generation.

- 1) 严禁直接焊接引线或设备到电池上。
- 2) 极片在焊接引线之前应该先点焊到电池上, 直接与电池热焊接, 产生的热量会使电池的隔离体及绝缘体受损。

11.2 Prevention of short circuit within a battery pack/电池内部的短路预防

Enough insulation layers between wiring and the cells shall be used to maintain extra safety protection. The battery pack shall be structured with no short circuit within the battery pack, which may cause generation of smoke or firing.

在电池和引线之间应该有足够的绝缘层用于安全保护。电池的包装构成应没有导致起烟起火的短路情况。

11.3 Prohibition of disassembly/禁止拆卸

- 1) Never disassemble the cells

The disassembling may generate internal short circuit in the cell, which may cause gassing, firing, explosion, or other problems.

- 2) Electrolyte is harmful

LIR battery should not have liquid from electrolyte flowing, but in case the electrolyte come into contact with the skin, or eyes, physicians shall flush the electrolyte immediately with fresh water and medical advice is to be sought.

- 1) 不要拆卸电池。
拆卸电池会发生电池内部短路, 会引起起火、爆炸、有害气体或者其它问题。
- 2) 电解液是有害的
万一电解液沾到皮肤、进入眼睛, 应立即用清水冲洗以及求助医生。

11.4 Prohibition of dumping of cells into fire/不要把电池倾倒在火中

Never incinerate nor dispose the cells in fire. These may cause explosion of the cells, which is very dangerous and is prohibited.

不要焚毁电池, 否则会致电池爆炸, 这个很危险, 必须禁止。

11.5 Prohibition of cells immersion into liquid such as water/禁止浸泡电池

The cells shall never be soaked with liquids such as water, seawater, drinks such as soft drinks, juices, coffee or others. 请不要把电池浸泡在液体当中, 像清水、海水, 及非酒精饮料、果汁、咖啡或者其它的饮料。

11.6 Battery cells replacement/更换电池

The battery replacement shall be done only by either cells supplier or device supplier and never be done by the user.

更换电池应由电池生产商或设备供应商完成, 用户不要自行更换。

11.7 Prohibition of use of damaged cells/禁止使用损坏的电池

The cells might be damaged during shipping by shock. If any abnormal features of the cells are found such as damages in a plastic envelop of the cell, deformation of the cell package, smelling of an electrolyte, an electrolyte leakage and others, the cells shall never be used any more.

The Cells with a smell of the electrolyte or a leakage shall be placed away from fire to avoid firing or explosion.

电池可能在出货途中碰撞而受损。如果发现电池有异常，例如包装损坏、电池包裹变形，有电解液的味道、发现漏液等等，不要再使用这些电池。

电池如果有电解液的味道或者出现漏液，电池放置应该远离火源避免起火及爆炸。

12 Period of Warranty/保质期

The period of warranty is one year from the date of shipment. Hai Lei guarantees to give a replacement in case of cells with defects proven due to manufacturing process instead of the customer abuse and misuse.

电池的保质期从出货之日算起为一年。如果电池的缺陷是在制造过程中形成的而不是由于用户滥用及错误使用造成，本公司负责退换电池。

13 Storage of the Batteries/电池的存放

The batteries should be stored at room temperature, charged to about 30% to 50% of capacity.

We recommend that batteries be charged about once per half a year to prevent over discharge.

电池应当在室温下存放，应充到 30%至 50%的电量。如长时间储存，建议每半年充一次电以防止电池过放电。

14 Other The Chemical Reaction/其它化学反应

Because batteries utilize a chemical reaction, battery performance will deteriorate over time even if stored for a long period of time without being used. In addition, if the various usage conditions such as charge, discharge, ambient temperature, etc. are not maintained within the specified ranges the life expectancy of the battery may be shortened or the device in which the battery is used may be damaged by electrolyte leakage. If the batteries cannot maintain a charge for long periods of time, even when they are charged correctly, this may indicate it is time to change the battery.

由于电池是利用化学反应的原理，所以随时间的增加电池的性能会降低，即使是存放很长一段时间而不使用。如果使用条件如充电、放电及周围环境温度等情形不在指定的使用范围内，会使缩短电池的使用寿命，或者会产生漏液导致设备损坏。如果电池长期不能充电，即使充电方法正确，这样需要更换电池了。

15 Note/注释

Any other items which are not covered in this specification shall be agreed by both parties.

本说明书未包括事项应由双方协议确定。