

**COEN026R
+ KFIC026**

**ELECTRIC DIRECT STEAM COMBI OVEN - 6 x 2/3 GN
+ KIT FOR BUILT-IN REMOVABLE OVEN**



MULTILEVEL



JUST IN TIME



AUTOCLIMA



FAST-DRY



ECOSPEED



ECOVAPOR



AUTOMATIC WASHING



ECO WASH



NABOOK CLOUD



SYNCHRONISATION



REMOTE SERVICE



ENERGY MONITOR



WATER-SOFTENER
MONITOR

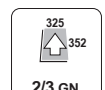

2/3 GN

TECHNICAL DATA

Capacity	GN	6 x 2/3	Power supply voltage	V	3N-AC 400
Distance between layers	mm	60	Frequency	Hz	50
Number of meals		20 / 50	Consumption	Amp	9
External dimensions Assembled kit (oven + kit)	mm	600 x 675 x 1310 h			
Weight Assembled kit (oven + kit)	kg	124	Extraction hood		
Total electric power	kW	5,5	Flow rate max	m³/h	900
Chamber heating output	kW / kcal	5 / -	Total electric power	kW	0,3
Fan power	kW	0,20	Noisiness max	db (A)	70

The 026R models are available in request with 1N-AC 230 V - 2,75 kW or 1N-AC 230 V - 3,7 kW voltage

KIT COMPOSITION

FOR MODEL **COEN026R** THIS IS A PRACTICAL AND INNOVATIVE SOLUTION FOR RECESSED INSTALLATION ANYWHERE, EVEN IN HOUSEHOLD SETTINGS. THE KIT, ENTIRELY IN STAINLESS STEEL, FEATURES A RECESSED FRAME, EXTENDABLE RAILS, OVEN ROTATION SYSTEM, EXTRACTION HOOD AND BUFFER FRAME. POSSIBILITY TO PULL THE OVEN OUT AND TURN IT 90° FROM BOTH SIDES, FOR CORRECT INSTALLATION, SCHEDULED AND UNSCHEDULED MAINTENANCE. THE COOKING VAPOURS ARE EXTRACTED BY THE EXTRACTION HOOD WITH AIR-COOLED CONDENSER SUPPLIED (1N-AC 230 V - 0,3 KW). IN ORDER TO USE THIS SOLUTION, THE UNIT MUST BE EQUIPPED WITH THE OPTIONAL **NPK** (CONFIGURATION FOR CONNECTION TO EXTRACTION HOOD), NO RETROFIT IS POSSIBLE.

THE **COEN026R** MODEL CAN BE INSTALLED ON STANDARD 60 X 60 CM HOUSEHOLD KITCHEN MODULES.

COOKING MODES

- ICS (INTERACTIVE COOKING SYSTEM), AN AUTOMATIC COOKING SYSTEM FOR ITALIAN AND INTERNATIONAL RECIPES INCLUDING THEIR HISTORY, INGREDIENTS, PROCEDURE, AUTOMATIC COOKING PROGRAM AND PLATE PRESENTATION.
- MANUAL COOKING WITH THREE COOKING MODES: CONVECTION FROM 30°C TO 300°C, STEAM FROM 30°C TO 130°C, COMBINATION CONVECTION + STEAM FROM 30°C TO 300°C, WITH INSTANT COOKING START.
- PROGRAMMABLE MODES: POSSIBILITY TO PROGRAMME AND SAVE COOKING METHODS IN AN AUTOMATIC SEQUENCE (UP TO 15 CYCLES) GIVING EACH PROGRAMME ITS OWN NAME, PICTURE AND INFORMATION ON THE RECIPE.
- MULTILEVEL AND JIT MODE.
- MULTILEVEL PLUS: DOUBLING THE MULTI-LEVEL FUNCTION ON EACH SHELF MEANS DOUBLING PRODUCTION CAPACITY.
- AUTOCLIMA® AUTOMATIC SYSTEM FOR MEASURING AND CONTROLLING THE HUMIDITY IN THE COOKING CHAMBER.
- FAST-DRY® SYSTEM FOR QUICK DEHUMIDIFICATION OF THE COOKING CHAMBER.

NABOOK WI-FI CONNECTIVITY

- RECIPE CREATION INCLUDING INGREDIENTS WITH PROCEDURE AND PHOTO.
- DIRECT ACCESS FROM COOKING DEVICE TO RECIPE DATABASE, WITH OPTIONAL DOWNLOAD.
- MENU CREATION WITH CALORIE COUNT AND LIST OF ALLERGENS WITH LAYOUT FOR CUSTOMISED PRINT OUT.
- FOOD COST CALCULATION OF RECIPES AND SINGLE PORTION MENUS.
- ORGANISATION OF SHOPPING LIST TO EXPORT IN PDF, EXCEL AND WORD FORMAT.
- SYNCHRONISATION OF DEVICES CONNECTED TO THE SAME ACCOUNT.
- HACCP MONITORING.
- REMOTE SERVICE.
- SOFTWARE UPDATE.

OPERATION

- DISPLAY THAT CAN BE CONFIGURED BASED ON THE USER'S NEEDS, BRINGING FORWARD THE PROGRAMMES USED MOST.
- AUTOMATIC "ONE TOUCH" COOKING (ICS).
- ORGANISATION OF RECIPES IN FOLDERS WITH PREVIEW, GIVING EACH FOLDER ITS OWN NAME.
- INTELLIGENT RECOGNITION OF RECIPES IN MULTILEVEL FOLDERS.
- 7" COLOUR SCREEN (LCD, HIGH DEFINITION, CAPACITIVE, WITH "TOUCH SCREEN" FUNCTIONS).
- SCROLLER PLUS KNOB WITH SCROLL AND PUSH FUNCTION FOR CONFIRMING CHOICES.
- INSTANTANEOUS DISPLAY IN ICS COOKING OF THE HACCP GRAPHIC.

CONTROL MECHANISMS

- AUTO REVERSE (AUTOMATIC REVERSE OF FAN ROTATION) FOR PERFECT COOKING UNIFORMITY.
- AUTOMATIC PARALLEL COMPARTMENT AND CORE TEMPERATURE CONTROL, DELTA T SYSTEM.
- AUTOMATICALLY REGULATED STEAM CONDENSATION.
- EASY ACCESS TO PROGRAMMABLE USER PARAMETERS TO CUSTOMISE THE APPLIANCE THROUGH THE USER MENU.
- PROGRAMMABLE DEFERRED COOKING.
- 2 FAN SPEEDS, THE REDUCED SPEED DECREASES HEATING POWER. FOR SPECIAL COOKING METHODS, YOU CAN USE AN INTERMITTENT SPEED.
- TEMPERATURE CONTROL AT THE PRODUCT CORE USING PROBE WITH 4 DETECTION POINTS.
- 2 CORE PROBE.
- CORE PROBE CONNECTION THROUGH A CONNECTOR OUTSIDE OF THE COOKING CHAMBER, WITH THE POSSIBILITY OF QUICKLY CONNECTING THE NEEDLE PROBE FOR VACUUM COOKING AND SMALL PIECES.
- USB CONNECTION TO DOWNLOAD HACCP DATA, UPDATE SOFTWARE AND LOAD/DOWNLOAD COOKING PROGRAMMES.
- POSSIBILITY OF SETTING DEVICE SWITCH-OFF AT THE END OF THE AUTOMATIC WASH PROGRAM.
- PRE-CONFIGURED SN ENERGY OPTIMISATION SYSTEM (OPTIONAL).
- SELF-DIAGNOSIS BEFORE STARTING TO USE THE EQUIPMENT, WITH DESCRIPTIVE AND AUDIBLE SIGNALLING OF ANY ANOMALIES.
- ECOSPEED - BASED ON THE QUANTITY AND TYPE OF PRODUCT, THE OVEN OPTIMISES AND CONTROLS THE ENERGY OUTPUT, MAINTAINING THE BEST COOKING TEMPERATURE AND AVOIDING FLUCTUATIONS.
- ECOVAPOR - WITH THE ECOVAPOR SYSTEM, THERE IS A NET REDUCTION IN WATER AND ENERGY CONSUMPTION DUE TO THE AUTOMATIC CONTROLS OF THE STEAM SATURATION IN THE COOKING CHAMBER.
- ENERGY MONITOR - MONITORING SYSTEM OF ENERGY, GAS, WATER, CLEANING CHEMICALS.
- EXTERNAL WATER-SOFTENER'S EFFICIENCY MONITORING SYSTEM (WATER-SOFTENER OPTIONAL).

CONSTRUCTION

- STAINLESS STEEL 18/10 AISI 304 OF 1 MM COOKING COMPARTMENT WITH LONG RADIUS ROUNDED CORNERS FOR A PERFECT CLEANING.
- PERFECTLY SMOOTH, WATERTIGHT CHAMBER.
- DOOR WITH DOUBLE TEMPERED GLASS WITH AIR CHAMBER AND INTERIOR HEAT-REFLECTING GLASS FOR LESS HEAT RADIATION TOWARDS THE OPERATOR AND GREATER EFFICIENCY.
- INTERNAL GLASS THAT FOLDS TO OPEN FOR EASY CLEANING.
- HANDLE WITH LEFT OR RIGHT HAND OPENING.
- ADJUSTABLE HINGE FOR OPTIMAL SEAL.
- DEFLECTOR THAT CAN BE OPENED FOR EASY FAN COMPARTMENT CLEANING.
- PUSH-IN TYPE OVEN FRONT PANEL SEAL MADE WITH HEAT AND AGE RESISTANT SILICON RUBBER.
- BUILT-IN DOOR DRIP TRAY COLLECTING THE CONDENSATE INTO THE OVEN DRIP TRAY; THEN INTO THE OVEN DRAIN.
- FRONT REMOVABLE CONTROL PANEL FOR EASY SERVICE AND CHECK OF MAIN COMPONENTS.
- TWO WATER INLETS (SOFT AND COLD WATER).
- IPX4 RATED PROTECTION AGAINST WATER SPRAY, PROVIDES A HIGHLY WATER RESISTANT FRONT PANEL AND CONTROLS.
- COOLING AIR CONVEYOR FOR FLUSH MOUNT.

ELECTRIC HEATING SYSTEM

- COOKING COMPARTMENT HEATING ELEMENTS OF ARMoured INCOLOY 800 TYPE.

SAFETY FEATURES

- COOKING COMPARTMENT SAFETY THERMOSTAT.
- COOKING COMPARTMENT SAFETY DEVICE FOR PRESSURE BUILT-UP AND DEPRESSION.
- FAN MOTOR THERMIC PROTECTION.
- MECHANICAL DOOR SWITCH.
- LACK OF WATER DISPLAYED ALARM.
- SELF-DIAGNOSIS AND FAULT DISPLAY.
- COMPONENT COOLING SYSTEM WITH OVERHEAT DISPLAY CONTROL.

CLEANING AND MAINTENANCE

- AUTOMATIC CLEANING SYSTEM LCS (LIQUID CLEAN SYSTEM) WITH BUILT-IN TANK AND AUTOMATIC DISPENSING (COMBICLEAN LIQUID CLEANSER IN 100% RECYCLABLE CARTRIDGES. SUPPLIED WITH 1 LIQUID CLEANSER CARTRIDGE CDL05 - 990 GR.).
- MANUAL CLEANING SYSTEM WITH EXTERNAL HAND SHOWER.

COOKING STEAM EXTRACTION HOOD (DOES NOT ELIMINATE COOKING ODOURS)

- AIR-COOLED CONDENSER WITH THERMAL DISCHARGE
- TWO-SPEED EXTRACTION MOTOR
- AUTOMATIC CONTROL
- LOW SPEED DURING COOKING
- AUTOMATIC HIGH SPEED ACTIVATION FOR 30" WHEN DOOR IS OPENED
- FRONT FILTERS CAN BE REMOVED FOR CLEANING
- CAN BE ATTACHED TO THE CENTRALISED EXTRACTION SYSTEM

STANDARD EQUIPMENT

- AUTOMATIC CLEANING SYSTEM LCS - SUPPLIED WITH 1 LIQUID CLEANSER CARTRIDGE CDL05 - 990 GR.
- MULTIPOINT CORE PROBE Ø 3 MM.
- WI-FI CONNECTION.
- USB CONNECTION.
- SIDE RUNNERS.









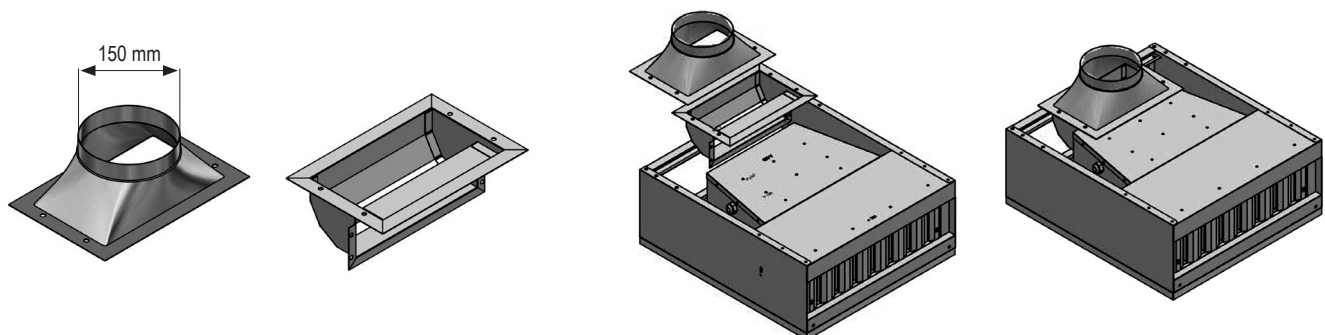

OPTIONAL - TO BE REQUESTED WHEN ORDERING OVEN

- **NPS:** OPPOSITE HINGED DOOR.
- **APDS:** DOUBLE RELEASE DOOR OPENING.
- **CETH:** EXTRA CHARGE FOR ETHERNET CONNECTION.
- **SN:** EXTRA CHARGE FOR ENERGY SAVING SYSTEM CONNECTION.
- **ADLS:** AUTOMATIC DOOR LOCKING SYSTEM (PREVENTS ACCIDENTAL OPENING OF THE DOOR DURING COOKING).
- **CCE:** COLLECTOR FOR EXTERNAL CONNECTION - Ø 150 MM

EXTRA ACCESSORIES THAT CAN BE INSTALLED FOLLOWING PURCHASE

- **KSA001:** NEEDLE CORE PROBE Ø 1 MM.
- **KSM002:** MULTIPROBES SYSTEM, 2 MULTIPOINT CORE PROBES. Ø 3 MM.
- **ICFX01:** FAT FILTER.

COLLECTOR FOR EXTERNAL CONNECTION - Ø 150 mm**- OPTIONAL -****CERTIFICATIONS**

-  Electric power supply cable inlet
-  Gas inlet and type of thread
-  Flue pipe
-  Boiler descaling cap
-  Steam vent and chamber pressure drop safety device
-  Oven steam vent
-  Air extraction
-  Normal water inlet
-  Softened water inlet
-  Liquid outlet
-  Steam trap

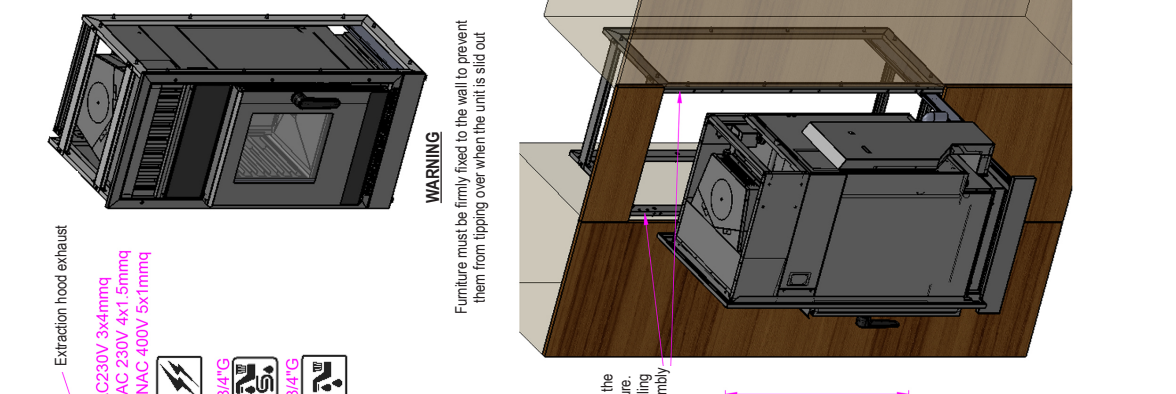
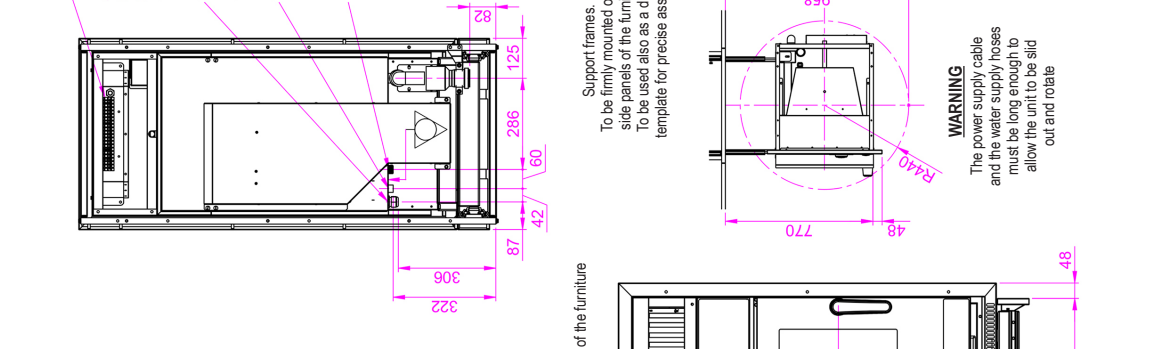
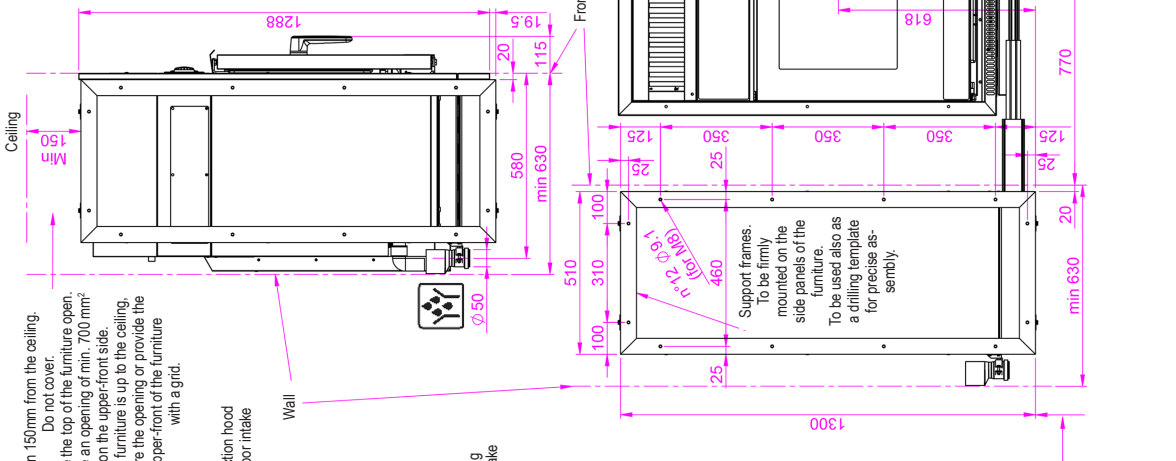
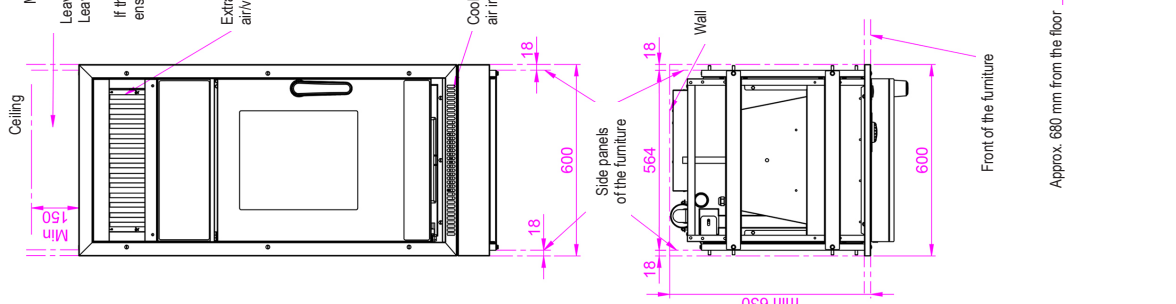

The data reported in this document is to be considered non-binding. The company reserves the right to make changes at any time, without prior notice

28.07.2020